

SX-ULPGN-BTZ

Low Power WiFi , BLE ,15.4 Single-Chip SoC



Highly Integrated Multi-Radio Host-less Platform for IoT

SX-ULPGN-BTZ is a dual band a/b/g/n Wi-Fi , Bluetooth low energy (BLE) , 802.15.4 combo module for the Internet-of-Things (IoT). It is a single stream 1x1 WLAN , BLE 5 + 802.15.4 based on Qualcomm's QCA4020 System-on-Chip (SoC). It enables seamless integration of three popular wireless connectivity technologies (802.11, Bluetooth and 802.15.4) used in the majority of today's IoT applications. The cost optimized single-chip solution, includes advanced hardware-based security features and a low power architecture targeted at meeting the demands of the latest IoT applications. The SDK's available for the SX-ULPGN-BTZ provide pre-integrated support for OCF specifications as well as support for AWS and MS Azure cloud connectivity.

Developed to address the expanding demands of embedded IoT applications the device is suited for single chip gateways, energy management, lighting, industrial automation, white goods appliances, home security and many other applications requiring multi-radio functionality.

Key Features

- Dual Band 802.11 a/b/g/n Wi-Fi + Bluetooth Low Energy + 802.15.4 connectivity (Zigbee, Thread PRO R21)
- Ecosystem Support: Amazon AWS, OpenThread, Microsoft Azure
- Supports WPA and WPA2 Enterprise Security. LEAP, EAP-FAST, EAP-TLS, PEAP, EAP-TTLS supported
- Integrated multi-radio co-Existence : 15.4+BLE+Wi-Fi co-existence on 2 antennas
- Configurable memory retention for minimizing deep sleep power per application
- Three dedicated internal processors remove the need for an external CPU/MCU:
 - ARM Cortex-M4F@128 MHz for user applications + 300KB SRAM
 - ARM Cortex-M0@64 MHz for BLE, 15.4 lower level MAC
 - Xtensa7 WLAN processor to run complete Wi-Fi stack
- Integrated PMU to generate power supplies for internal circuitry either from an external battery or a 3.3 V supply

Specifications

Product Name	SX-ULPGN-BTZ-2000
Application CPU	ARM Cortex M4 @ 128MHz 32KB L1 cache 300+KB RAM
Connectivity CPU	ARM Cortex M0 @ 64MHz for BT LE and 15.4 MAC CPU Dedicated 802.11a/b/g/n MAC CPU Isolated RAM and ROM
I/O Interfaces	SPI, HSUART, USB, PWM, I2C, I2S, SDIO, ADC, GPIO
WLAN Technology	802.11 a/b/g/n (Dual band)
Bluetooth Technology	BT LE v5
Data Rate	WLAN: Up to 150Mb/s
WLAN Channel Width	40 MHz
Dimension	28.5mm x 33.5mm x 4.5mm
WLAN Tx Power Out	Up to +17dBm
BLE Tx Power Out	Class II (External PA)
15.4 Tx Power Out	Up to 0dBm (External PA)
Power Supply	3.3VDC, 1.8VDC (Optional)
Operating Temperature	-20°C to 80°C
Security	WLAN supports WPA/WPA2 personal and enterprise, WPS2.0 Secure boot, Secure Storage, HW crypto engine, HW ECC, 16-bit True RNG, Trusted Execution Environment
Antenna	Integrated WLAN + BT/15.4 MDX connector for external WLAN + BT/15.4

Block Diagram

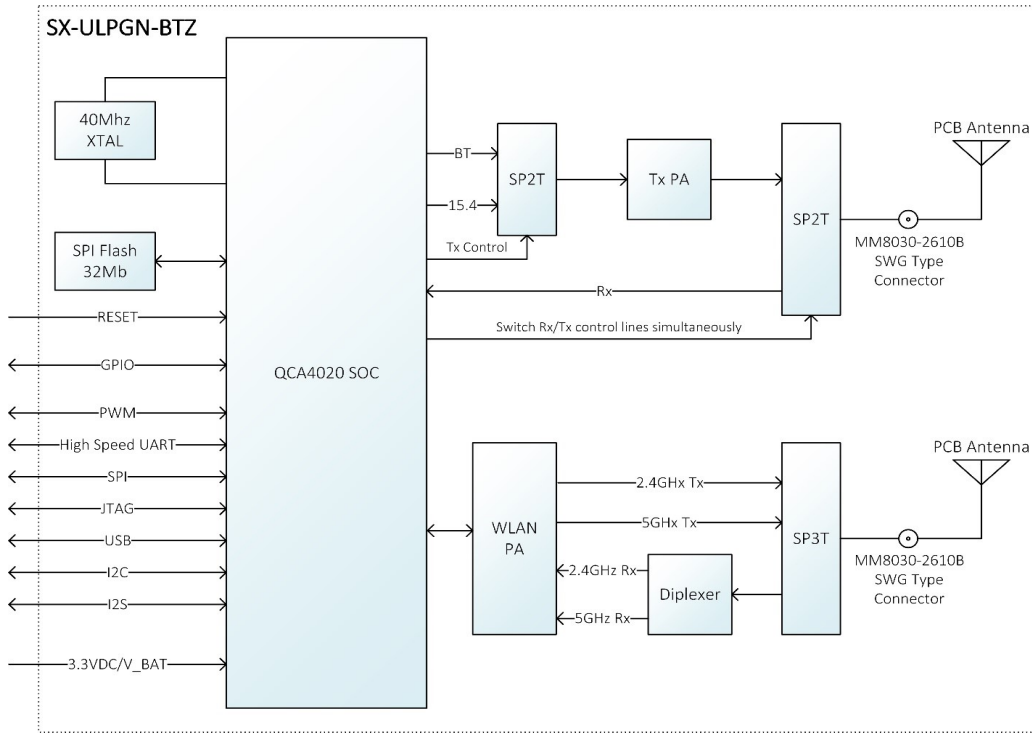

Software Features

- Available on Qualcomm Developer Network (QDN)
- Full IDE environment
- Complete peripheral support and functionality.
- Wide range of example applications and demo code.
- Regulatory testing support

Ordering Information

SX-ULPGN-BTZ-2000	Bulk Ordering
SX-ULPGN-BTZ-2000 -SP	Sample Pack
SX-ULPGN-BTZ -EVK	EVK for SX-ULPGN-BTZ module

EVK Features

- Evaluation base board for easy evaluation of the SX-ULPGN-BTZ module
- On-board FTDI2232 IC for 4-wire JTAG debugging
- Comprehensive set of headers, test-point for power measurement, direct connect to battery, boot-configuration, other measurements
- Reference design schematics and layout information available.
- Supports JTAG and USB factory programming interfaces.

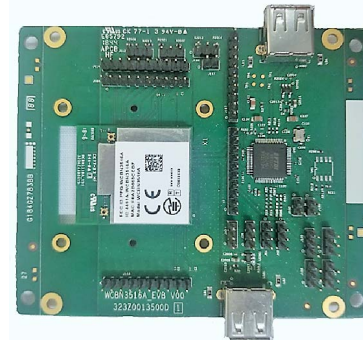

silex technology is a registered trademark of silex technology, Inc. Other product or brand names may be registered trademarks or trademarks of their respective owners. Technical information and specifications are subject to change without notice. © 2019 silex technology, Inc. All rights reserved.

silex global sales & support locations