

Protocol Converter for CNC Machines

FBR-100AN/FBR-100

User's Manual



Index

1. Introduction.....	1
1-1. Introduction	1
Disclaimers.....	1
Trademarks	1
1-2. Safety Instructions	2
1-3. Product Information and Customer Services	7
Product Information.....	7
Customer Support Center	7
2. Specifications	9
2-1. Features.....	10
2-2. Parts and Functions	11
2-3. Hardware Specifications	13
LED (Case Top)	14
DC Connector	16
LED (Network Port)	17
DIP Switch	18
Digital Input	19
Serial Port	20
2-4. Software Specifications.....	21
2-5. Wireless Specifications (Only for FBR-100AN)	23
2-6. Regulatory Compliance.....	25
2-7. Use of Radio Waves (Only for FBR-100AN).....	29
Notes on Usage	29
2-8. Notes on Security (Only for FBR-100AN).....	31
2-9. Safe Handling of Antenna (Only for FBR-100AN).....	32
3. How to Configure FBR-100AN/FBR-100.....	33
3-1. Sample Connections	34
Individual Networks (Edge Mode).....	34

Bridged Network (Bridge Mode).....	35
3-2. Before You Begin.....	37
3-2-1. Necessary Items (Only for Initial Configuration)	37
Necessary Items	37
Power ON	37
Changing Network Setting of PC	38
3-2-2. Displaying FBR-100AN/FBR-100's Web Page.....	39
3-3. Basic Configuration.....	42
3-3-1. Basic Configuration	42
Edge Setting.....	44
Bridge Setting.....	46
3-3-2. Detailed Bridge Setting (Only for FBR-100AN)	48
3-4. Using Wireless Station Function (Only for FBR-100AN)	51
3-4-1. Connecting Access Point by Using 'Easy Configuration'.....	52
3-4-2. Connecting Access Point by Using 'Detailed Configuration'.....	55
IEEE802.1X Authentication	57
3-5. Using AMC Manager® to Configure	59
3-6. Installing and Using FBR-100AN/FBR-100	60
4. List of Functions	61
4-1. Showing System Status.....	62
4-2. Showing Wireless LAN(STA) Status(Only for FBR-100AN)	63
4-3. Showing MTConnect Status	64
4-4. Using MTConnect.....	65
4-4-1. What is MTConnect?.....	65
Agent and Adapter	66
Data Collection Method.....	67
4-4-2. MTConnect Setting.....	68
MTConnect setting	68
Network Collection Setting	72
4-4-3. Checking Collected Machine Tool Data	78
List of HTTP Requests	78

Sample of MTConnect Client Utility	80
4-4-4. Collecting Information of Stack Tower Light Using AirGRID®	81
4-5. FTP Setting.....	82
4-6. Time Setting	84
4-7. Serial Setting	86
4-8. Login Password Change.....	88
4-9. IP Address Filter.....	90
4-10. MAC Address Filter	93
4-11. Log Output.....	95
4-12. Packet Capture.....	96
5. Maintenance Feature.....	99
5-1. Factory Default Configuration.....	100
5-1-1. Factory Default Configuration Using Web Page	100
5-1-2. Factory Default Configuration Using Push Switch.....	102
5-2. Restart	103
5-2-1. Restart by Unplugging Cables.....	103
5-2-2. Restart Using Web Page.....	104
How to Restart FBR-100AN/FBR-100 Using Web Page.....	104
5-3. Firmware Update.....	106
5-3-1. Downloading Latest Firmware	106
5-3-2. How to Update Firmware	107
A. Appendix.....	111
A-1. List of All Settings	112
A-1-1. Network Configuration.....	112
General - General Configuration.....	112
General - Bridge Detailed Configuration (Only for FBR-100AN).....	116
Wireless LAN (STA) - Easy Configuration (Only for FBR-100AN).....	117
Wireless LAN (STA) - Detailed Configuration (Only for FBR-100AN).....	118
MTConnect Configuration - Common Configuration	123
MTConnect Configuration - Network Configuration.....	124

MTConnect Configuration - Network Configuration - Default Point Configuration....	126
MTConnect Configuration - Network Configuration - Custom Point Configuration...	129
MTConnect Configuration - DPRNT Configuration	135
MTConnect Configuration - agent Mode Configuration.....	136
MTConnect Configuration - AirGRID® Configuration	137
FTP Configuration	138
Time Configuration.....	139
A-1-2. Serial Configuration	140
General Configuration.....	140
A-1-3. Security Configuration.....	142
Login Password Configuration	142
IP Address Filter Configuration.....	142
MAC Address Filter Configuration.....	144
A-2. List of Error Codes.....	145
A-3. Activation.....	148
A-3-1. Registering Activation Key	148
A-3-2. Clearing Activation Key	150
A-4. Using OPC UA Activation	151
A-4-1. What is OPC UA?.....	151
A-4-2. Network Connection to Use OPC UA Activation	152
A-4-3. Showing OPC UA Status	153
A-4-4. OPC UA Setting.....	154
A-5. Using Modbus TCP Activation.....	156
A-5-1. Features of Modbus TCP.....	156
A-5-2. Communication for Using Modbus TCP Activation.....	157
A-5-3. Showing Modbus TCP Status.....	158
A-5-4. Modbus TCP Setting	159

1. Introduction

Thank you for purchasing FBR-100AN/FBR-100, the MTConnect-compatible protocol converter for CNC devices.

1-1. Introduction

This manual explains how to configure and use the following products.

- FBR-100AN
- FBR-100

The wireless LAN feature can be used with FBR-100AN only.

Please read the **1-2. Safety Instructions** carefully before you begin.

Disclaimers

- The unauthorized transfer or copying of the content of this manual, in whole or in part, without prior written consent is expressly prohibited by law.
- The content of this manual is subject to change without notice.
- The screen display may vary depending on the FBR-100AN/FBR-100 firmware version, or the operating system, Web browser and its version of the PC. Some instructions may not be applicable.
- Although every effort was made to prepare this manual with the utmost accuracy, Silex Technology will not be held liable for any damages as a result of errors, setting examples, or other content.



Trademarks

- AMC Manager® is a registered trademark of Silex Technology.
- AirGRID® is a registered trademark of PATLITE Corporation.
- Modbus® is a registered trademark of Schneider Electric USA Inc.
- Microsoft Edge is a trademark or registered trademarks of Microsoft Corporation in the United States and/or other countries.
- Wi-Fi, WPA (Wi-Fi Protected Access), WPA2 are trademarks or registered trademarks of Wi-Fi Alliance.
- Other company names and product names contained in this manual are trademarks or registered trademarks of their respective companies.







1-2. Safety Instructions

This page provides the safety instructions for safe use of FBR-100AN/FBR-100. To ensure safe and proper use, please read the following information carefully before using FBR-100AN/FBR-100.



< Meaning of the warnings >

	Danger	"Danger" indicates an imminently hazardous situation that could result in death or serious injury if the safety instruction is not observed.
	Warning	"Warning" indicates the existence of a hazard that could result in death or serious injury if the safety instruction is not observed.
	Caution	"Caution" indicates the existence of a hazard that could result in serious injury or material damage if the safety instruction is not observed.



< Meaning of the symbols >

	This symbol indicates the warning and caution. (Example:  "Danger of the electric shock")
	This symbol indicates the prohibited actions. (Example:  "Disassembly is prohibited")
	This symbol indicates the actions users are required to observe. (Example:  "Remove the AC plug from an outlet")

 **Danger**



	<ul style="list-style-type: none">• Do not use this product in a place where flammable gas is generated. It may cause an explosion, fire, electric shock or malfunction.• Make sure that foreign objects (metal, combustibles, liquids, etc.) do not get into this product. It may cause fire or electric shock.• Do not install this product in an unstable place or do not stop installation halfway. This product may fall.• Do not use this product with the equipment that directly affects the human life (medical equipment such as the life support equipment and operating room equipment) and with the system that has a significant impact on the human safety and the maintenance of public functions (nuclear equipment, aerospace equipment, etc.).
	<ul style="list-style-type: none">• Do not disassemble or modify this product. It may cause fire, electrical shock or malfunction.• Do not disassemble or modify the AC adaptor (sold separately). It may cause fire, electrical shock or malfunction.
	<ul style="list-style-type: none">• If this product is not used according to the given instructions, the protection function may be lost.• Use the correct power voltage. Improper voltage may cause fire or an electrical shock.

 **Warning**

	<ul style="list-style-type: none"> • In the following cases, turn off the connected devices and unplug the DC cable or AC plug of this product from a power outlet. Failure to follow these instructions may cause fire or an electrical shock. <ul style="list-style-type: none"> - When this product emits a strange smell, smoke or sound or becomes too hot to touch. - When foreign objects (metal, liquid, etc.) gets into this product. - When this product is dropped or the case is broken or cracked.
	<ul style="list-style-type: none"> • Do not place anything on top of this product. Also, do not place this product on top of the other product. Failure to do so may cause fire, electrical shock, malfunction or performance degradation. • Do not cover up this product with a cloth such as blanket or table cloth. The heat remains inside and it may cause fire or malfunction. • Do not place any objects on top of AC adapter or DC cable, or do not cover it up with anything. Also, do not use the AC adapter on top of the heat/moisture retaining materials (carpet, sponge, cardboard, styrofoam, etc.). The accumulated heat may result in fire or malfunction. • Do not roll up or wrap DC cable or AC cord. It may cause fire or an electrical shock. • Do not plug or unplug AC adaptor or DC cable with wet hands. It may cause an electrical shock or malfunction. • Do not move this product when AC adapter or DC cable is connected to it. The cable may be damaged, and which may result in fire or electric shock.
	<ul style="list-style-type: none"> • For use of the devices connected to this product, please follow all warnings, cautions and notices given by that manufacturer and carefully use them in a proper manner. Failure to follow these instructions may cause fire, electrical shock or malfunction. • If a ground wire is supplied with your device to use with, connect it to the ground terminal in order to prevent an electrical shock. Do not connect the ground wire to gas pipe, water pipe, lighting rod or telephone ground wire. It may cause malfunction. • Keep the cords and cables away from children. It may cause an electrical shock or serious injury. • Make sure that you have a secure scaffold when this product is installed or removed to/from a high place. There is a danger of falling.

 **Caution**

- Use the AC adaptor designated by Silex Technology. Other AC adaptors may cause malfunction.
- Do not place any objects on the cable, pinch the cable between walls and shelves, bend, twist or pull the cord strongly.
- Do not use or store this product under the following conditions. It may cause malfunction.
 - Locations subject to vibration or shock
 - Shaky, uneven or tilted surfaces
 - Locations exposed to direct sunlight
 - Humid or dusty places
 - Wet places (kitchen, bathroom, etc.)
 - Near a heater or stove
 - Locations subject to extreme changes in temperature
 - Near strong electromagnetic sources (magnet, radio, wireless device, etc.)
 - Poorly ventilated locations (on bookshelf, rack, etc.)
 - Near chemical substance
- Do not step on this product. The product may be broken and it causes injury.
- Do not place the cables in a place where many people walk by. They may trip over the cables and get injured.
- Do not use or store this product in an extremely humid or dusty place. When using this product in such an environment, please install it on a dust-proof control panel, etc..
- Do not touch this product and connectors with wet hands. There is a danger of electric shock.
- Do not pull on the cable or AC cord to disconnect the DC cable or AC plug of the connected device or this product. The cable or cord may be broken, which could result in fire or an electrical shock.

	<ul style="list-style-type: none">• This product may become hot when it is in use. Be careful of the heat when moving or removing this product.• Follow the law of each country when you discard this product.• Verify all cords or cables are plugged correctly before using this product.• When installing this product to a high position, make sure that this product is firmly fixed so it does not drop for weight of the cables.• Use this product under the appropriate operating conditions (temperature, humidity, vibration, shock).• When this product malfunctions or shows abnormal operation, turn off it and contact the point of purchase or Silex Technology's customer support.• Be sure to use a shield cable to connect the peripheral equipment.• When this product gets dirty, wipe it gently with a soft cloth using water or neutral detergent. Using volatile solvents (benzene, thinner, etc.) or chemicals may cause peeling or discoloration of the paint.• When connecting the cables, check the shape of the connectors to make sure they are connected to the right direction.• When using this product in a place subject to effects of overcurrent or overvoltage (lightning surge, etc.), use the proper surge protection device (SPD) for all connectors (power line, LAN, RS-232C, RS-422, RS-485, DI, earth, etc.). For selection/installation of SPD, please contact the specialized contractor.
	<ul style="list-style-type: none">• When removing this product, disconnect the DC cable or AC plug of the connected device or this product from the outlet.• When this product will not be used for a long time, unplug the DC cable or AC plug of the connected device or this product.

Silex Technology, Inc. shall not be responsible for any loss or damage you may suffer as a result of using this product (regardless of if it is described in this safety instruction or not).

1-3. Product Information and Customer Services

Product Information

The services below are available from the Silex Technology website. For details, please visit the Silex Technology website.

URL	
USA / Europe	https://www.silextechnology.com/

- Latest firmware download
- Latest software download
- Latest manual download
- Support information (FAQ)

Customer Support Center

Customer Support is available for any problems that you may encounter. If you cannot find the relevant problem in this manual or on our website, or if the corrective procedure does not resolve the problem, please contact Silex Technology Customer Support.

Contact Information	
USA	support@silexamerica.com
Europe	support@silexeurope.com



Note

- Visit the Silex Technology website (<https://www.silextechnology.com/>) for the latest FAQ and product information.

(blank page)

2. Specifications

FBR-100AN/FBR-100 is a converter that monitors CNC machine tools and transfers the operating status to the factory monitoring system/server.

As the MTConnect communication is supported, which is the standard feature adopted by factory device manufacturers of the United States, CNC machine tools can efficiently be connected to the host system. By using a wired/wireless bridge function, cableless network can be established in a factory where cable wiring is not always easy.

Connection Image

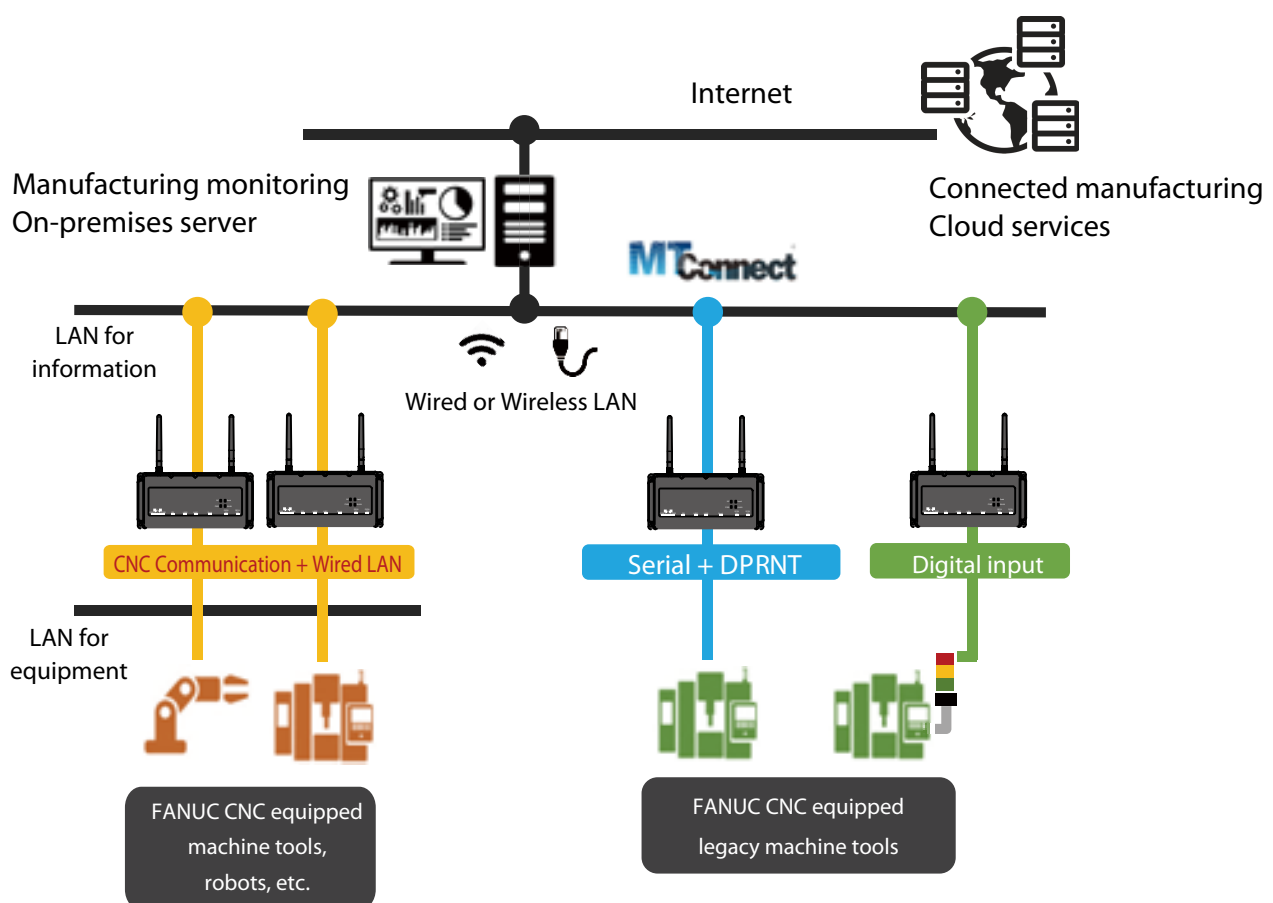

- The wireless LAN feature can be used with FBR-100AN only.

TIP

2-1. Features

FBR-100AN/FBR-100 has the following features:

- Sends the machine tool information in MTConnect format to the upper server system.
- Supports both wired LAN (2 interfaces) and wireless LAN (1 interface). The wired/wireless LAN interfaces can be bridged (only for FBR-100AN).
- From acquisition of machine tool status through establishment of cableless network over wireless LAN, various kinds of work can be performed (only for FBR-100AN).
- It is possible to freely define and configure the setting to retrieve the operating information from the FANUC CNC.
- As Serial I/F and digital input are supported, old models (legacy machine tool with FANUC CNC) can be connected.
- IP53 compatibility allows installation to outside of the control panel.
- SDK (non-free program) can be used to implement a special communication function and add a simple edge application.
- Supports the unified management software, AMC Manager[®] (non-free program) / AMC Manager[®] Free (free program).
- AirGRID[®] (the wireless communication system developed by PATLITE Corporation) can be used for operation monitoring.
- By turning on FBR-100AN/FBR-100 while the DIP Switch 4 is ON, the activation key can be registered. If the activation key is registered, the optional function (non-free) can be enabled. (For details on the optional function, refer to the product catalogue or visit the Silex Technology's website.)



- Specifications of serial I/F and digital input differ for each device manufacturer. Customization may be required depending on the device.



- For details on the AMC Manager[®], please visit our website.

2-2. Parts and Functions

The parts name and functions are as follows:

Front

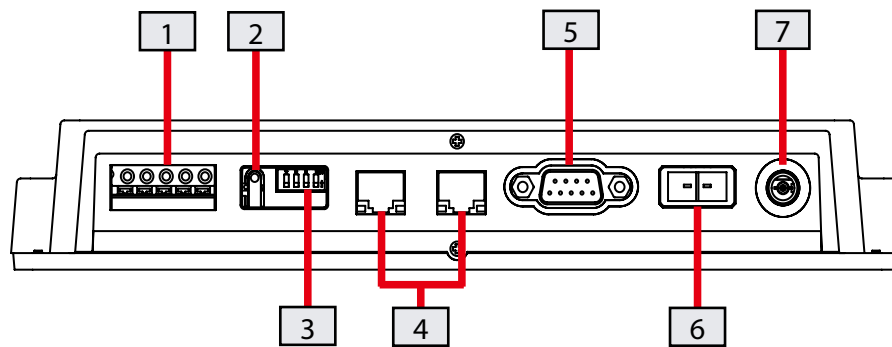

- 1 Digital input interface
- 2 Push switch
- 3 DIP switch
- 4 Network port
- 5 Serial port (RS-232C/422/485 connector)
- 6 DC connector
- 7 DC jack

Top

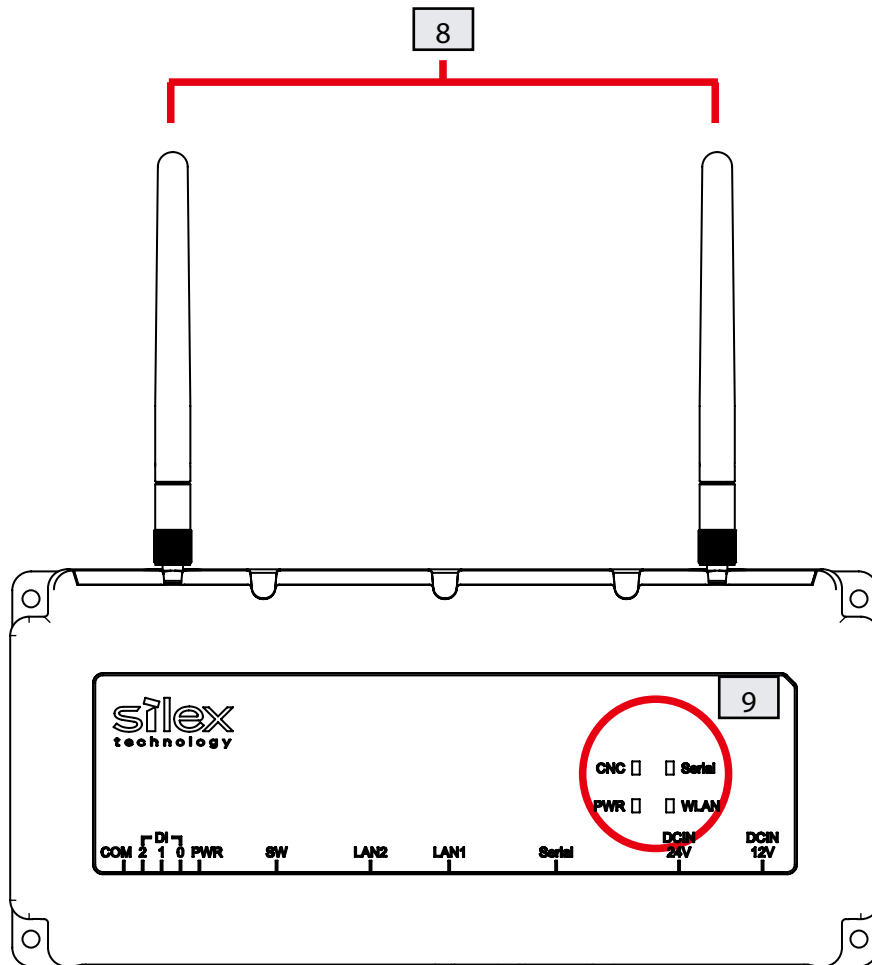

8 Antenna (Only for FBR-100AN)

9 Top LED

2-3. Hardware Specifications

Hardware Specifications

Wired LAN I/F	RJ-45 x 2 10Base-T / 100Base-TX / 1000Base-T x 2Port (Auto-sensing) AutoMDI/MDIX is supported.	
ROM	SPI Flash ROM 32MByte	
RAM	DDR3L SDRAM Memory 256MByte	
MMC	eMMC 2GByte (Pseudo SLC)	
LED	Network port	LED x 2
		Link LED : Green Status LED : Orange
	Top of the unit	LED x 4
		PWR(Power) LED : Red/Green/Orange WLAN LED : Red/Green/Orange Serial LED : Red/Green/Orange CNC LED : Red/Green/Orange
Push Switch	Push switch x 1	
	Dip switch x 4	
Antenna	Wireless LAN	External antenna 2.4GHz / 5GHz dual band
Dimension	W : 230mm x D : 105mm x H : 36mm (unit size)	
EMI	VCCI Class A FCC Class A ICES Class A CE / UKCA Class A	
Power	DC jack (DC 12Vin ±5%)	
	DC connector (DC 12-24Vin ±5%)	
Serial I/F	RS-232C/RS-422/RS-485 (D-Sub 9pin)	
Digital Input I/F	Photocoupler isolated input x 3	



Note

- For RS-485, only the physical interface is supported. To use RS-485, it needs to be added from the firmware.

Operating/Storage Environment

Operating environment	Temperature : -20°C to 50°C
	Humidity : 20% to 90%RH (Non-condensing)
Storage environment	Temperature : -20°C to 55°C
	Humidity : 20% to 90%RH (Non-condensing)



Note

- When wireless LAN is not used, or when a large amount of data is not transmitted or received continuously over wireless LAN (e.g. when only CNC operating status data is transferred), FBR-100AN/FBR-100 can withstand the temperature up to 55 degrees.

LED (Case Top)

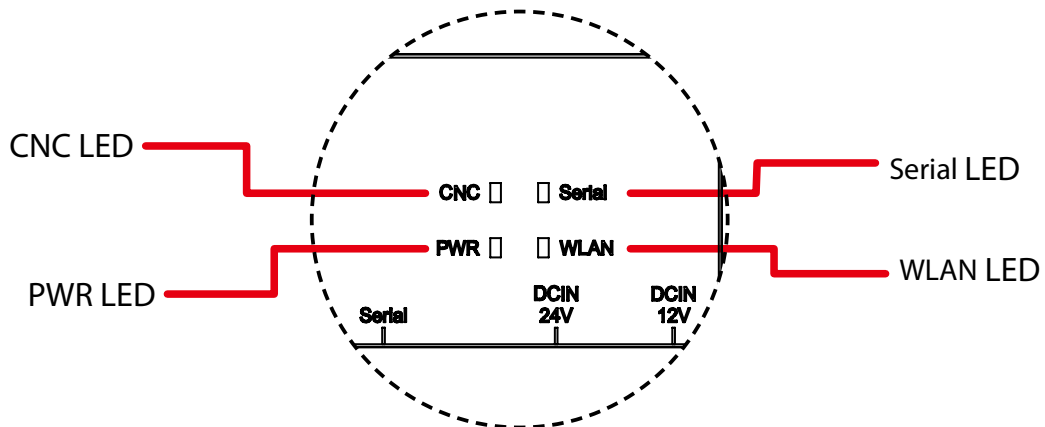

PWR LED

Shows the power status and operating status of FBR-100AN/FBR-100.

Status		Meaning
Off		FBR-100AN/FBR-100 is powered off.
Green	On	FBR-100AN/FBR-100 is powered on.
	Blink	Firmware update is in progress.
Orange	On	Factory default configuration is in progress (initialization / eMMC format)
	Blink	-
Red	On	(FBR-100AN/FBR-100 is started with a recovery firmware.)
	Blink	Hardware error - Wireless error - eMMC mount failure

WLAN LED (only for FBR-100AN)

Shows the network status.

Status		Meaning
Off		-
Green	On	FBR-100AN is connected to wireless LAN. (Signal strength: 3, RSSI: -63dBm or higher)
	Blink	Data communication is in progress. (Signal strength: 3, RSSI: -63dBm or higher)
Orange	On	FBR-100AN is connected to wireless LAN. (Signal strength: 2, RSSI: -78dBm to -64dBm)
	Blink	Data communication is in progress. (Signal strength: 2, RSSI: -78dBm to -64dBm)
Red	On	FBR-100AN is connected to wireless LAN. (Signal strength: 1, RSSI: -79dBm or lower)
	Blink	Data communication is in progress. (Signal strength: 1, RSSI: -79dBm or lower) Or wireless LAN is enabled but Access Point is not connected.



- To make sure of stable wireless communication, it is recommended to use FBR-100AN in the environment at which the WLAN LED turns green.

Serial LED

Shows the serial communication status.

Status		Meaning
Off		No serial communication is in progress.
Green	On	RS-232C is operating.
	Blink	RS-232C is handling data transmission/reception.
Orange	On	RS-422 is operating.
	Blink	RS-422 is handling data transmission/reception.
Red	On	Error status - Serial communication value error
	Blink	Data transmission/reception is in progress after the error status occurs.

CNC LED

Shows the CNC device connection status.

Status		Meaning
Off		CNC device or adapter device is not connected (IP address is not configured.)
Green	On	CNC device or adapter device is connected (Data collection is completed successfully.) When the data acquisition mode is AirGRID®, WDR is connected.
	Blink	-
Orange	On	-
	Blink	-
Red	On	Error status - Data acquisition failure
	Blink	-

DC Connector

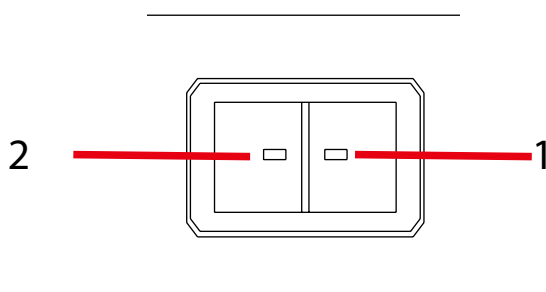

PIN Number	Signal Name	Description
1	DCIN	DC 12-24Vin ±5%
2	GND	GND

DC connector : JST S02B-F32SK-GGXR(LF)(AU)

For this connector, please use JST JFA connector J300 series F32FSS-02V-KX.

LED (Network Port)

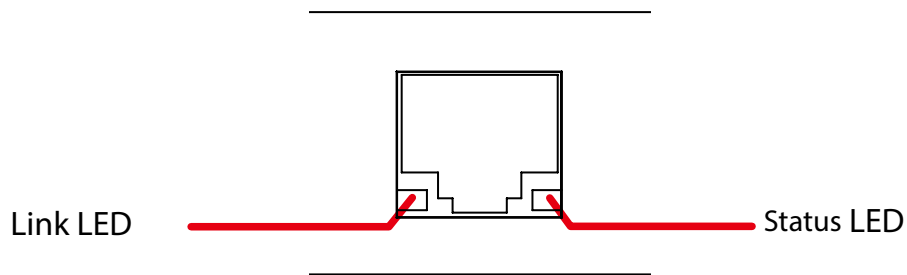

Link LED

Shows the wired LAN link status.

Status		Meaning
Green	On	Wired LAN is linked.
	Off	Wired LAN is not linked.

Status LED

Shows the wired LAN communication status.

Status		Meaning
Orange	Blink	The packet is received from wired LAN.

DIP Switch

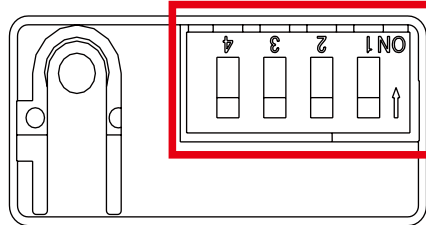

Switch Number	Function
1	Switches the serial mode. On: RS-422 Off: RS-232C
2	Switches the serial termination resistor. On: Serial termination (120Ω for RXD signal) Off: None
3	Not in use
4	Enables/Disables activation for the optional function (non-free). On : Enable (The activation key needs to be registered.) Off : Disable

Digital Input

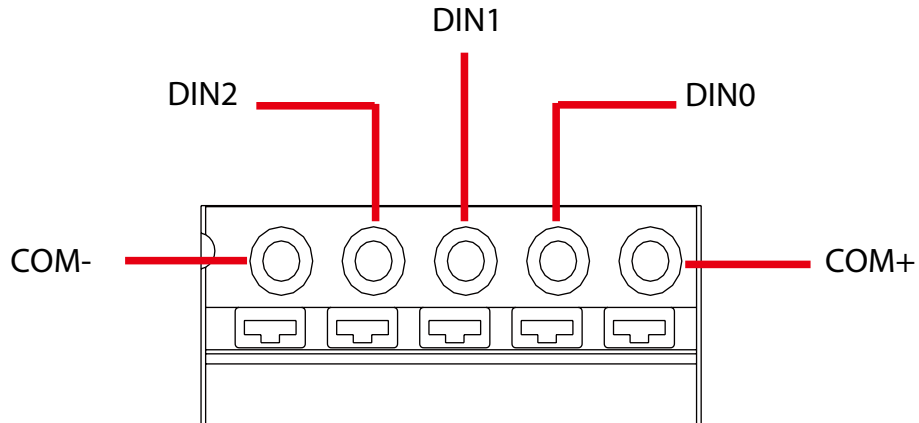

Signal	Note
DIN0	Turns ON when the external input is Low, and turns OFF when it is High.
DIN1	
DIN2	

Input equivalent circuit

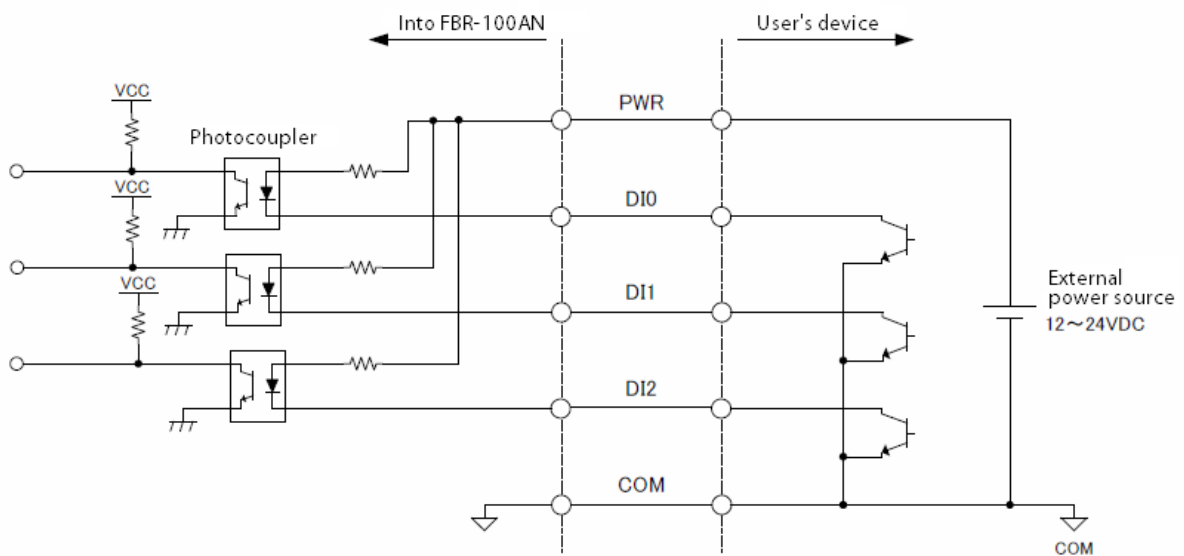

Serial Port

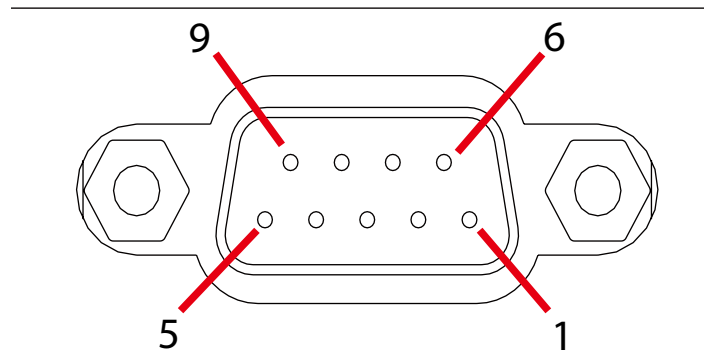

PIN Number	RS-232C	RS-422/RS-485
1	DCD [in]	TxD- [out]
2	RxD [in]	TxD+ [out]
3	TxD [out]	RxD+ [in]
4	DTR [out]	RxD- [in]
5	GND [-]	GND [-]
6	DSR [in]	-
7	RTS [out]	-
8	CTS [in]	-
9	RI [in]	-

2-4. Software Specifications

Basic Protocols	Network Layer	ARP, IP, ICMP, FLDP
	Transport Layer	TCP, UDP
	Application Layer	DHCP, HTTP, NTP, TFTP, HTTPS, FTP(C/S), JCP, MTConnect(ver 1.3.1), SXSMP * JCP and SXSMP are Silex Technology's proprietary protocols.
Recommended Web Browser	Microsoft Edge	
Supported Languages	English/Japanese	
Recommended MTConnect utility	FANUC MTLINKi (ver 3.6)	
Recommended FTP server compatible utility	FFFTP (ver 2.0.0)	

FANUC CNC Compatible Models

<p>Network compatible</p>	<p>FANUC Series 30i-MODEL B FANUC Series 31i-MODEL B FANUC Series 31i-MODEL B5 FANUC Series 32i-MODEL B FANUC Series 35i-Model B</p> <p>FANUC Series 30i-MODEL A FANUC Series 31i-MODEL A FANUC Series 31i-MODEL A5 FANUC Series 32i-MODEL A</p> <p>FANUC Series 0i-M/T MODEL F FANUC Series 0i-M/T MODEL D</p> <p>FANUC Series 16i/18i/21i</p> <p>* To access the CNC device using FOCAS1/2, the Ethernet function is required.</p>
<p>Serial/DPRNT compatible</p>	<p>FANUC Series 15 FANUC Series 16/18/20/21 FANUC Power Mate -D/F/H FANUC Series 16i/18i/21i FANUC Power Mate i FANUC Series 15i FANUC Series 0i FANUC Series 30i/31i/32i</p> <p>* Depending on the configuration of CNC device or machine tool, DPRNT may not be supported.</p>

2-5. Wireless Specifications (Only for FBR-100AN)

Wireless LAN I/F

IEEE802.11a	Frequency	5GHz band
	Transmission Method	OFDM
	Transmission Rate	54 / 48 / 36 / 24 / 18 / 12 / 9 / 6 (Mbps)
	Channel	[US] W52 : 36, 40, 44, 48 W53 : 52, 56, 60, 64 W56 : 100, 104, 108, 112, 116, 132, 136, 140 W58 : 149, 153, 157, 161, 165 [EU] W52 : 36, 40, 44, 48 W53 : 52, 56, 60, 64 W56 : 100, 104, 108, 112, 116, 120, 124, 128, 132, 136, 140
IEEE802.11b	Frequency	2.4GHz band
	Transmission Method	DS-SS
	Transmission Rate	11 / 5.5 / 2 / 1 (Mbps)
	Channel	[US]1-11ch [EU]1-13ch
IEEE802.11g	Frequency	2.4GHz band
	Transmission Method	OFDM
	Transmission Rate	54 / 48 / 36 / 24 / 18 / 12 / 9 / 6 (Mbps)
	Channel	[US]1-11ch [EU]1-13ch
IEEE802.11n (5GHz)	Frequency	5GHz band
	Transmission Method	MIMO-OFDM
	Transmission Rate	MCS0, 1, 2, 3, 4, 5, 6, 7 (1Stream) MSC8, 9, 10, 11, 12, 13, 14,15 (2Stream)
	Channel	[US] W52 : 36, 40, 44, 48 W53 : 52, 56, 60, 64 W56 : 100, 104, 108, 112, 116, 132, 136, 140 W58 : 149, 153, 157, 161, 165 [EU] W52 : 36, 40, 44, 48 W53 : 52, 56, 60, 64 W56 : 100, 104, 108, 112, 116, 120, 124, 128, 132, 136, 140

IEEE802.11n (2.4GHz)	Frequency	2.4GHz band
	Transmission Method	MIMO-OFDM
	Transmission Rate	MCS0, 1, 2, 3, 4, 5, 6, 7 (1Stream) MSC8, 9, 10, 11, 12, 13, 14,15 (2Stream)
	Channel	[US]1-11ch [EU]1-13ch

Wireless Security

STA Mode (Wireless Station)	Open (WEP 64/128Bit) Shared (WEP 64/128Bit) WPA2-PSK (AES) WPA/WPA2-PSK (TKIP/AES) WPA2-EAP (AES) WPA/WPA2-EAP (TKIP/AES)
--------------------------------	--

2-6. Regulatory Compliance

■ Notice to US Customers



Contains FCC ID: N6C-SXPCEAN2

FCC CAUTION

Changes or modifications not expressly approved by the party responsible for compliance could void the user's authority to operate the equipment.

This device complies with part 15 of the FCC Rules. Operation is subject to the following two conditions:

- (1) This device may not cause harmful interference.
- (2) this device must accept any interference received, including interference that may cause undesired operation.

Subpart C §15.247 and Subpart E

This equipment complies with FCC radiation exposure limits set forth for an uncontrolled environment and meets the FCC radio frequency (RF) Exposure Guidelines. This equipment should be installed and operated keeping the radiator at least 20cm or more away from person's body.

Subpart E §15.407(c)

Data transmission is always initiated by software, which is the passed down through the MAC, through the digital and analog baseband, and finally to the RF chip. Several special packets are initiated by the MAC. These are the only ways the digital baseband portion will turn on the RF transmitter, which it then turns off at the end of the packet. Therefore, the transmitter will be on only while one of the aforementioned packets is being transmitted. In other words, this device automatically discontinue transmission in case of either absence of information to transmit or operational failure.

Frequency Tolerance: +/-20 ppm

CO-Location Rule

This device and its antenna(s) must not be co-located or operation in conjunction with any other antenna or transmitter.

FCC Rules Part 15 Subpart B Class-A

Note: This equipment has been tested and found to comply with the limits for a Class A digital device, pursuant to part 15 of the FCC Rules. These limits are designed to provide reasonable protection against harmful interference when the equipment is operated in a commercial environment. This equipment generates, uses, and can radiate radio frequency energy and, if not installed and used in accordance with the instruction manual, may cause harmful interference to radio communications. Operation of this equipment in a residential area is likely to cause harmful interference in which case the user will be required to correct the interference at his own expense.

■ Notice to Canadian Customers**CAN ICES-3(A)/NMB-3(A)****Contains IC : 4908A-SXPCEAN2**

This device contains licence-exempt transmitter(s)/receiver(s) that comply with Innovation, Science and Economic Development Canada's licence-exempt RSS(s). Operation is subject to the following two conditions:

1. This device may not cause interference
2. This device must accept any interference, including interference that may cause undesired operation of the device.

L'émetteur/récepteur exempt de licence contenu dans le présent appareil est conforme aux CNR d'Innovation, Sciences et Développement économique Canada applicables aux appareils radio exempts de licence. L'exploitation est autorisée aux deux conditions suivantes :

1. L'appareil ne doit pas produire de brouillage;
2. L'appareil doit accepter tout brouillage radioélectrique subi, même si le brouillage est susceptible d'en compromettre le fonctionnement.

RSS-Gen Issue 5 §6.8

This radio transmitter (4908A-SXPCEAN2) has been approved by Innovation, Science and Economic Development Canada to operate with the antenna types listed below, with the maximum permissible gain indicated. Antenna types not included in this list that have a gain greater than the maximum gain indicated for any type listed are strictly prohibited for use with this device.

Antenna type	Gain	Impedance
Pole antenna (TD17039A0S0)	2.4GHz : 1.5dBi 5GHz : 2.1dBi	50Ω

Le présent émetteur radio (4908A-SXPCEAN2) a été approuvé par Innovation, Sciences et Développement économique Canada pour fonctionner avec les types d'antenne énumérés ci-dessous et ayant un gain admissible maximal. Les types d'antenne non inclus dans cette liste, et dont le gain est supérieur au gain maximal indiqué pour tout type figurant sur la liste, sont strictement interdits pour l'exploitation de l'émetteur.

Type d'antenne	Gain	l'impédance
Antenne pôle(TD17039A0S0)	2.4GHz : 1.5dBi 5GHz : 2.1dBi	50Ω

RSS-247 Issue 2 §6.2.2.2

for indoor use only (5150-5350 MHz)

Pour usage intérieur seulement (5150-5350 MHz)

RSS-247 Issue 2 §6.4

Data transmission is always initiated by software, which is then passed down through the MAC, through the digital and analog baseband, and finally to the RF chip. Several special packets are initiated by the MAC. These are the only ways the digital baseband portion will turn on the RF transmitter, which it then turns off at the end of the packet. Therefore, the transmitter will be on only while one of the aforementioned packets is being transmitted. In other words, this device automatically discontinues transmission in case of either absence of information to transmit or operational failure.

La transmission des données est toujours initiée par le logiciel, puis les données sont transmises par l'intermédiaire du MAC, par la bande de base numérique et analogique et, enfin, à la puce RF. Plusieurs paquets spéciaux sont initiés par le MAC. Ce sont les seuls moyens pour qu'une partie de la bande de base numérique active l'émetteur RF, puis désactive celui-ci à la fin du paquet. En conséquence, l'émetteur reste uniquement activé lors de la transmission d'un des paquets susmentionnés. En d'autres termes, ce dispositif interrompt automatiquement toute transmission en cas d'absence d'information à transmettre ou de défaillance.

RSS-102

This equipment complies with ISED radiation exposure limits set forth for an uncontrolled environment and meets RSS-102 of the ISED radio frequency (RF) Exposure rules. This equipment should be installed and operated keeping the radiator at least 20cm or more away from person's body.

Cet équipement est conforme aux limites d'exposition aux rayonnements énoncées pour un environnement non contrôlé et respecte les règles d'exposition aux fréquences radioélectriques (RF) CNR-102 de l'ISDE. Cet équipement doit être installé et utilisé en gardant une distance de 20 cm ou plus entre le radiateur et le corps humain.

■ Notice to European Customers



AT	EE	IE	NL	ES	CH
BE	FI	IT	PL	SE	HR
BG	FR	LV	PT		MK
CY	DE	LT	RO	IS	TR
CZ	EL	LU	SK	LI	ME
DK	HU	MT	SI	NO	RS

■ Notice to UK Customers



Restrictions or Requirements in the UK

2-7. Use of Radio Waves (Only for FBR-100AN)

Notes on Usage

When using FBR-100AN near the medical devices

The radio wave interference may adversely affect the operation of medical devices such as pacemakers. When using FBR-100AN near the medical devices that require a high level of safety and reliability, check with the manufacturer or distributor of each medical device about the effects of radio waves.

When using FBR-100AN near the following devices

- Microwave oven, industrial/scientific equipment, etc.

The above devices use the same radio frequency band as the wireless LAN. Using FBR-100AN near the above devices may cause radio wave interference. As the result, communication may be lost, the speed may slow down, or the operation of the above devices may be adversely affected.

Before using FBR-100AN, make sure that no radio wave interference occurs. For example, if there is a microwave oven near FBR-100AN, check the proper communication beforehand while actually using the microwave oven.

Do not use FBR-100AN near a cellular phone, TV or Radio

A cellular phone, TV and radio use a different radio band than our products. Generally, if they are used near FBR-100AN, it will not cause any problems. However, when they approximate FBR-100AN, sound or image noise may occur.

If there is reinforced concrete/metal between wireless devices, they may not connect

FBR-100AN can connect through wood or glass, but may have troubles connecting through reinforced concrete/metal.

FBR-100AN complies with the certification of conformance to technical standards.

Please pay attention to the following points:

- Please do not disassemble or remodel the product. Such action is prohibited by law.
- Please do not remove the certificate label. Using the product without a label is prohibited.

Wireless devices using 2.4GHz band

The same frequency band of FBR-100AN is used for a microwave, industry, science, medical equipment and licensed in room or low power (non-licensed) radio stations.

- Before you use FBR-100AN, check that it does not interfere with other devices.
- If interference occurs, stop using FBR-100AN or change the wireless band. Please consider to create a wall between these devices to avoid interference. Contact us for possible solution.

* The meaning of the symbols in the bottom of the unit:

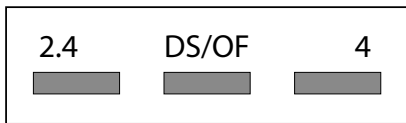

2.4	: Wireless devices using 2.4GHz frequency band
DS/OF	: DS-SS or OFDM is used as modulation.
4	: The range of interference is equal to or lower than 40m.
	: All bands can be used to avoid interference.

Notes on using 5GHz band

- Use of 5.2GHz band (W52) and 5.3GHz band (W53) outdoors is prohibited by the radio regulations.

2-8. Notes on Security (Only for FBR-100AN)

Because a wireless LAN uses electromagnetic signals instead of a LAN cable to establish communication with network devices, it has the advantage of allowing devices to connect to the network easily. However, a disadvantage of this is that within a certain range, the electromagnetic signals can pass through barriers such as walls, and if security countermeasures are not implemented in some way, problems such as the following may occur.

- Communication is intercepted by a third party
- Unauthorized access to the network
- Leakage of personal information (ID and Card information)
- Spoofing and the falsification of intercepted data
- System crashes and data corruption

Nowadays, wireless LAN cards or access points are equipped with security measures that address such security problems, so that you can enable security-related settings for wireless LAN products in order to reduce the likelihood of problems occurring.

We recommend that you make yourself fully acquainted with the possible implications of what might happen if you use a wireless product without enabling security features, and that you configure security-related settings and use wireless products at your own responsibility.

2-9. Safe Handling of Antenna (Only for FBR-100AN)

Please refrain from attaching or removing the antenna or changing the antenna angle frequently. Failure to do so will put a stress on the inside of the antenna and may cause malfunction.

When attaching or removing the antenna, turn only the knurled portion while holding the antenna portion with your hands. When adjusting the angle of the antenna, do not tilt it more than 180 degrees.

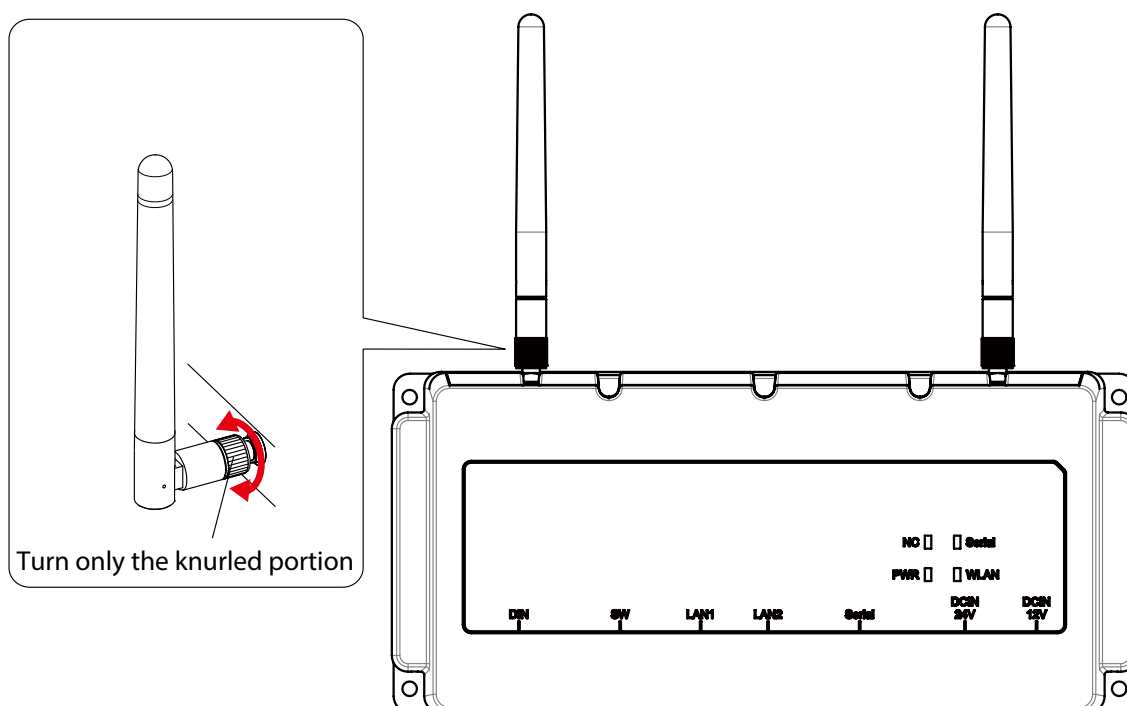

3. How to Configure FBR-100AN/FBR-100

This chapter explains how to configure FBR-100AN/FBR-100.

3-1. Sample Connections

Wired LAN (2 interfaces) and wireless LAN (1 interfaces) of FBR-100AN/FBR-100 can be used separately to configure the individual network. Also, it is possible to bridge the interfaces to configure the combined network. The followings are the sample connections. Configure FBR-100AN/FBR-100 appropriately for your environment.

Individual Networks (Edge Mode)

Assign IP address and subnet mask for each interface to configure individual network. In the Edge mode, the operating information can only be retrieved from the machine tools and be transferred to the PC. In the sample connection below, it is impossible to access the machine tools from PC-01 or PC-02.

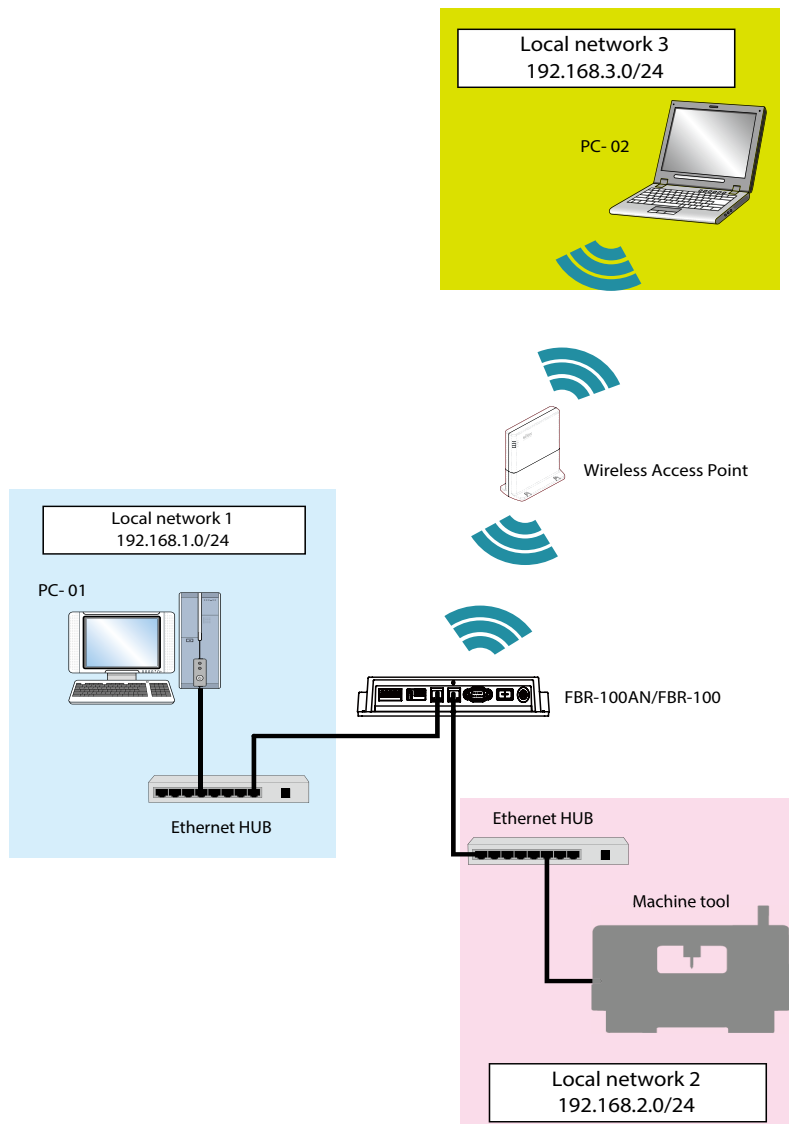

- The wireless LAN feature can be used with FBR-100AN only.

Bridged Network (Bridge Mode)

The wired devices can be connected to a wireless LAN environment.

By connecting the network HUB to a wired LAN port of FBR-100AN/FBR-100, up to 16 wired devices can be connected to the wireless LAN at the same time. For the MAC address to use for wireless LAN connection, the MAC address of FBR-100AN will be used.

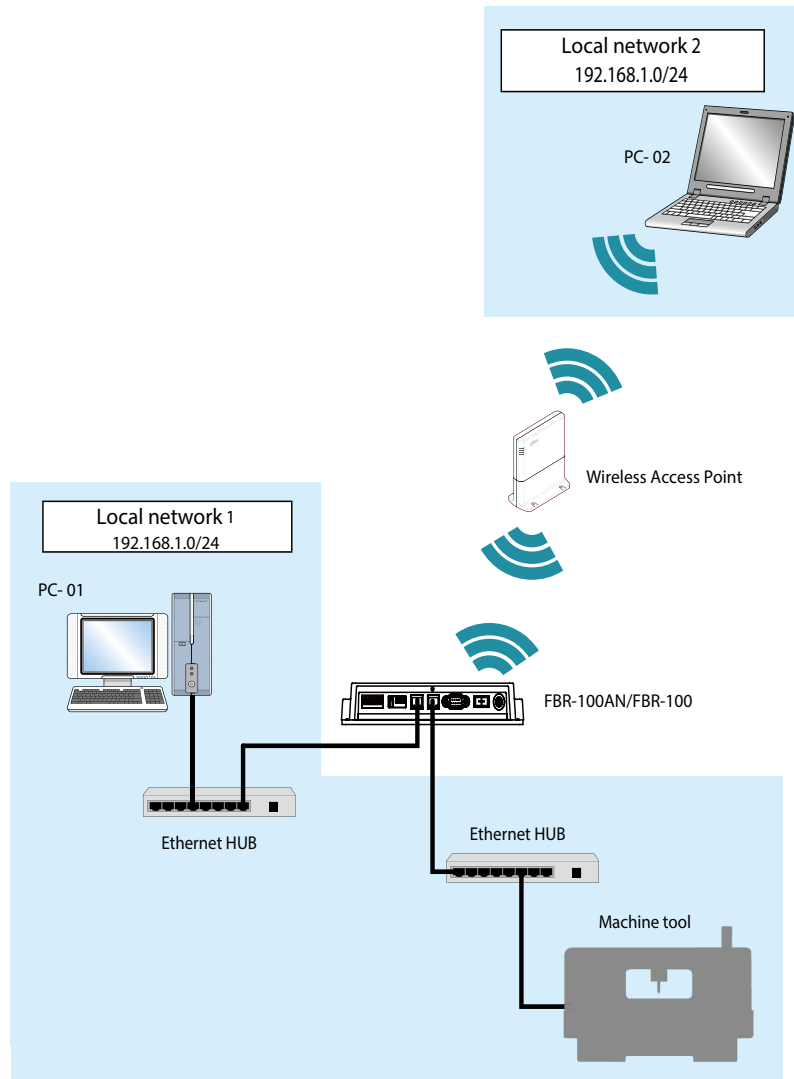

- The wireless LAN feature can be used with FBR-100AN only.

TIP

By selecting **Wired Only** for **Add to Bridge**, it is possible to enable the bridge for wired LAN only.

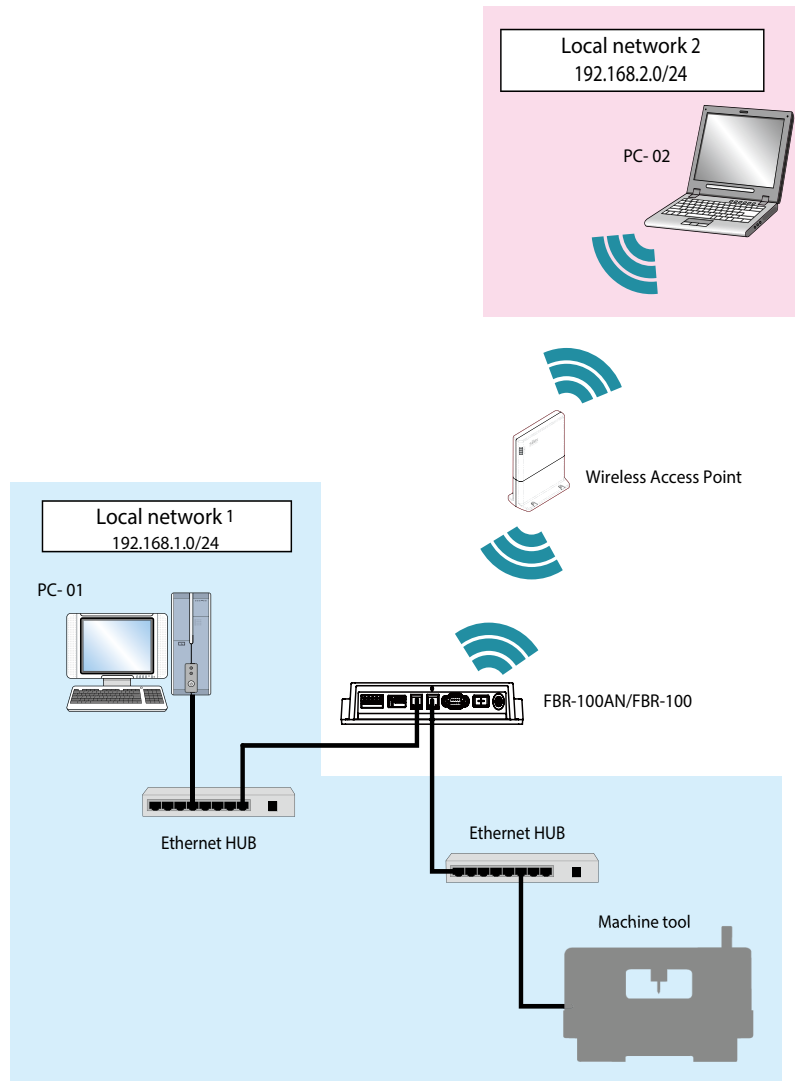

- The wireless LAN feature can be used with FBR-100AN only.

3-2. Before You Begin

The following explains the preparation for configuration.

3-2-1. Necessary Items (Only for Initial Configuration)

Necessary Items

Following items are required for initial configuration.

- PC
- LAN cable

Power ON

- 1.** Connect one end of LAN cable to LAN1 of FBR-100AN/FBR-100 and the other end to PC.

- 2.** Turn on FBR-100AN/FBR-100.
Confirm that the PWR LED turns green on top of FBR-100AN/FBR-100.

3. Turn on the PC.

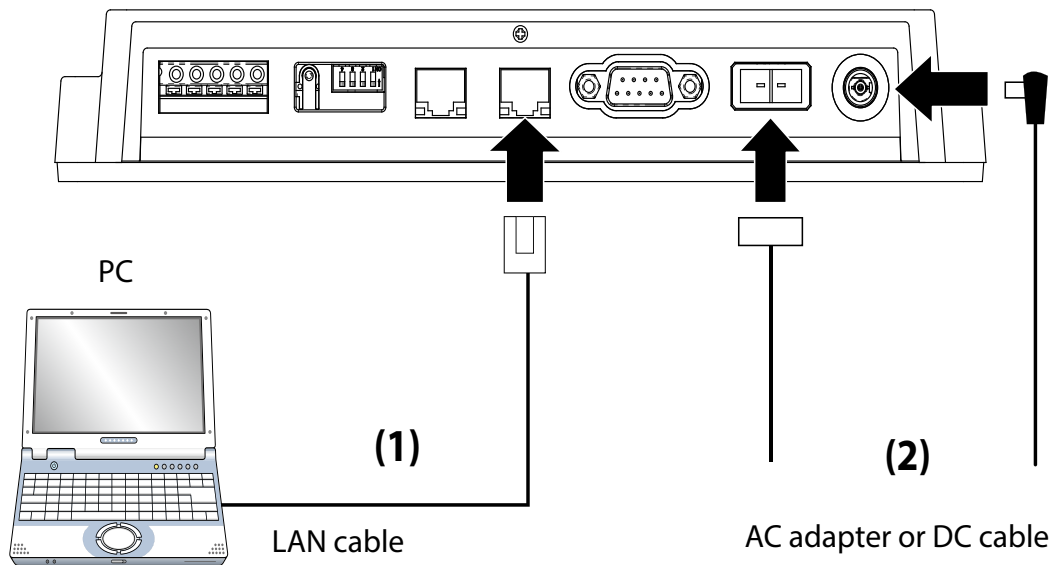

Changing Network Setting of PC

The following explains how to modify PC network settings so that you can access FBR-100AN/FBR-100 from your PC.

The default IP address of FBR-100AN/FBR-100 is 192.168.1.1 (Class C).

For the IP address of the PC, configure the different one that is not used by FBR-100AN/FBR-100.

Example) Network settings

Set up the network settings of your PC as follows:

IP address : 192.168.1.123

Subnet mask : 255.255.255.0

3-2-2. Displaying FBR-100AN/FBR-100's Web Page

The network settings of FBR-100AN/FBR-100 can be configured from its Web configuration interface. By entering the IP address of FBR-100AN/FBR-100 to the address bar of your Web browser, the Web configuration page can be accessed.

1. Start the Web browser on the PC.



Note

- For information on the compatible Web browser, refer to **2-4. Software Specifications**.

2. Enter the IP address of FBR-100AN/FBR-100 (**xxx.xxx.xxx.xxx**) to the address bar.



Note

- The default IP address of FBR-100AN/FBR-100 is "192.168.1.1".

3. The login password configuration page will be displayed. Enter the login password to configure for FBR-100AN/FBR-100 and click **Submit**.

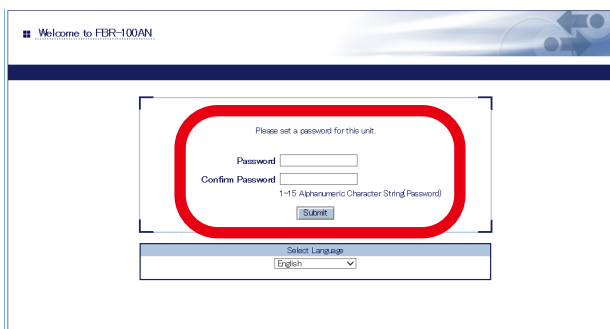

TIP

- The login password configuration page is displayed only when FBR-100AN/FBR-100 is configured for the first time.

- When the login page is displayed, enter the login password you have configured for Password and click **Login**.

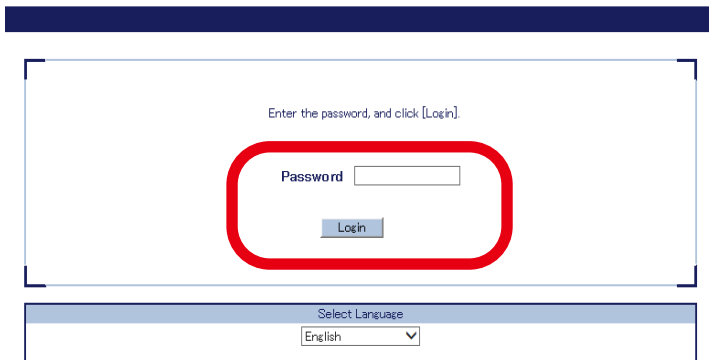

- When the Web page is displayed, select the network setting you want to configure from the configuration menu.

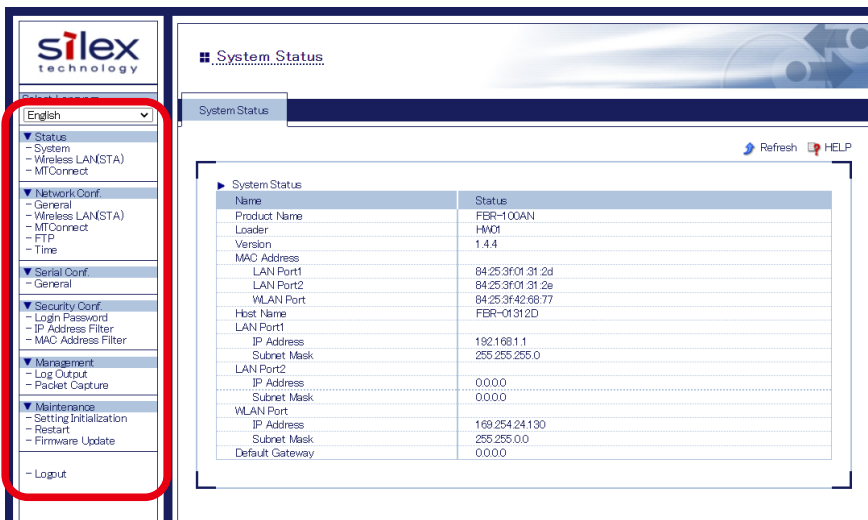

Configuration menu		Details
Select Language		Switches the language between English, Japanese, and Chinese.
Status	System	Shows the system information.
	Wireless LAN(STA)	Shows the wireless station setting. When a wireless interface is disabled, it is not displayed.
	MTConnect	Shows the MTConnect setting.

Configuration menu		Details
Network Conf	General	Configure the basic network setting.
	Wireless LAN(STA)	Configure the setting to use FBR-100AN as a wireless station.
	MTConnect	Configure the MTConnect setting.
	FTP	Configure the FTP setting.
	Time	Configure the time setting.
Serial Conf	General	Configure the serial setting.
Security Conf	Login Password	Login password can be changed.
	IP Address Filter	The access from the specified device to FBR-100AN/FBR-100 can be restricted using the IP address filter.
	MAC Address Filter	The access from the specified device to FBR-100AN/FBR-100 can be restricted using the MAC address filter.
Management	Log Output	Obtains the system log.
	Packet Capture	Obtains the network packet.
Maintenance	Setting Initialization	Executes the factory default configuration and then restarts FBR-100AN/FBR-100.
	Restart	Restarts FBR-100AN/FBR-100.
	Firmware Update	Updates the firmware.
Logout		Logs out the Web page.



- **Wireless LAN(STA)** is only for FBR-100AN.

TIP

3-3. Basic Configuration

3-3-1. Basic Configuration

Configure the network settings appropriate for your environment.

1. Open your Web browser and access the FBR-100AN/FBR-100's Web page.



Note

- For details on how to access the FBR-100AN/FBR-100's Web page using the Web browser, refer to **3-2-2. Displaying FBR-100AN/FBR-100's Web Page.**

2. Click **General** from the configuration menu.

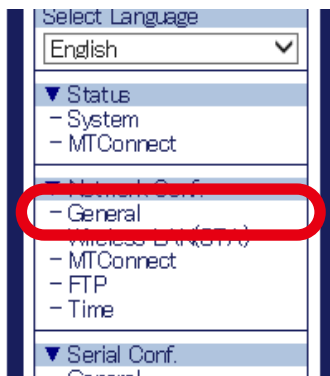

3. The **General Configuration** page is displayed.

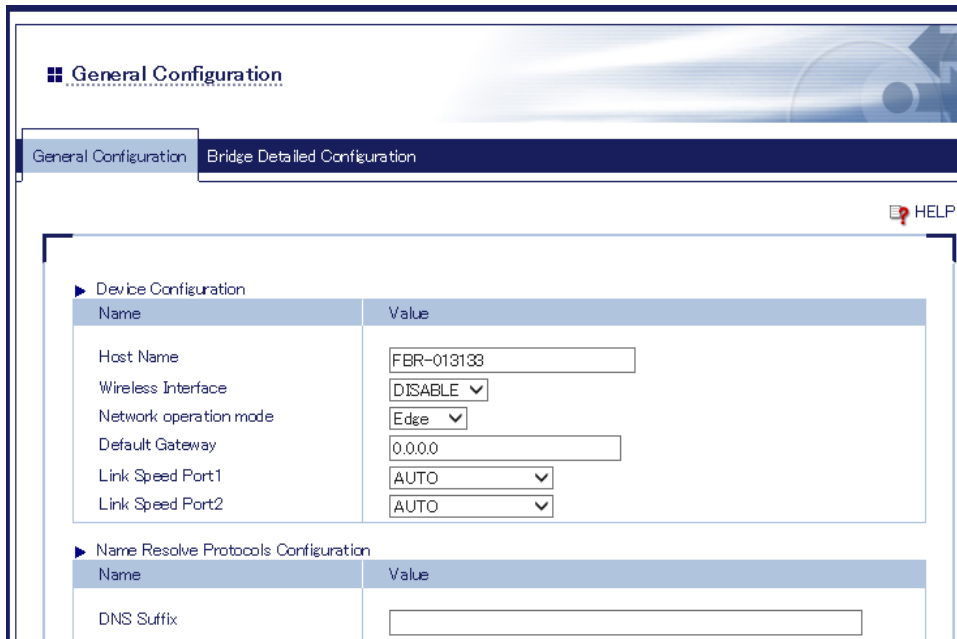

Device Configuration	
Name	Value
Host Name	FBR-013138
Wireless Interface	DISABLE
Network operation mode	Edge
Default Gateway	0.0.0.0
Link Speed Port1	AUTO
Link Speed Port2	AUTO

Name Resolve Protocols Configuration	
Name	Value
DNS Suffix	



- **Wireless Interface** is only for FBR-100AN.

Select the operation mode at **Network operation mode** appropriately for your environment. The setting items will differ depending on the selected operation mode.

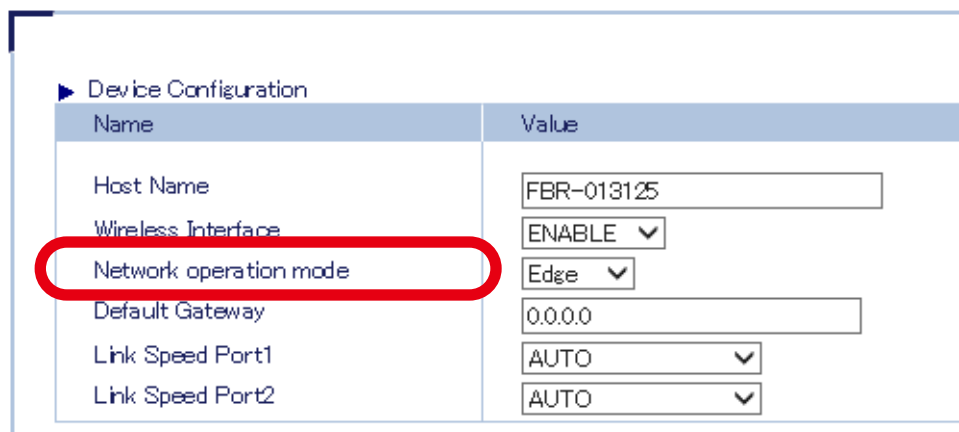

Device Configuration	
Name	Value
Host Name	FBR-013125
Wireless Interface	ENABLE
Network operation mode	Edge
Default Gateway	0.0.0.0
Link Speed Port1	AUTO
Link Speed Port2	AUTO

To configure the edge setting, select **Edge**.
To configure the bridge setting, select **Bridge**.

Edge Setting

Configure the IP address/subnet mask for each interface.

1. Select **Edge** for the **Network operation mode**.

Device Configuration	
Name	Value
Host Name	FBR-013125
Wireless Interface	ENABLE
Network operation mode	Edge
Link Speed Port1	AUTO
Link Speed Port2	AUTO

2. Configure each setting.

Name Resolve Protocols Configuration	
Name	Value
DNS Suffix	
DNS Server (Primary)	0.0.0.0
DNS Server (Secondary)	0.0.0.0

LAN Port1	
Interface Configuration	
Name	Value
DHCP Client	DISABLE
IP Address	172.25.73.206
Subnet Mask	255.255.252.0

LAN Port2	
Interface Configuration	
Name	Value
DHCP Client	DISABLE
IP Address	192.168.2.1
Subnet Mask	255.255.255.0

WLAN Port	
Interface Configuration	
Name	Value
DHCP Client	ENABLE
IP Address	0.0.0.0
Subnet Mask	0.0.0.0



- When **Edge** is selected for **Network operation mode**, set an IP address of different segment for LAN Port1 and LAN Port2. If an IP address of the same segment is set, it will be an error.



Note

- The WLAN port setting is displayed only when **ENABLE** is selected for **Wireless Interface** (only for FBR-100AN).

3. Check the settings and click **Submit**.



- The entered settings will be cleared if other configuration items are clicked on the menu. To save the entered settings, click **Submit**.

Note

- The new setting will take effect when FBR-100AN/FBR-100 is turned on next time.

4. The confirmation message for restart is displayed. To continue the configuration, click the setting item you want to configure from the menu. Click **Restart** to take effect of the new setting when the necessary configuration is finished.

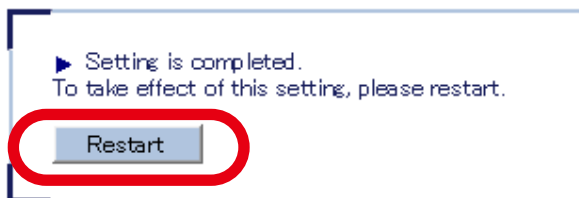

TIP

- Do not turn off FBR-100AN/FBR-100 when the restart is in progress.



Note

- FBR-100AN/FBR-100 can also be restarted by clicking **Restart** from the configuration menu.

5. When the restart is finished and the login page of FBR-100AN/FBR-100 is displayed again, the configuration is completed.

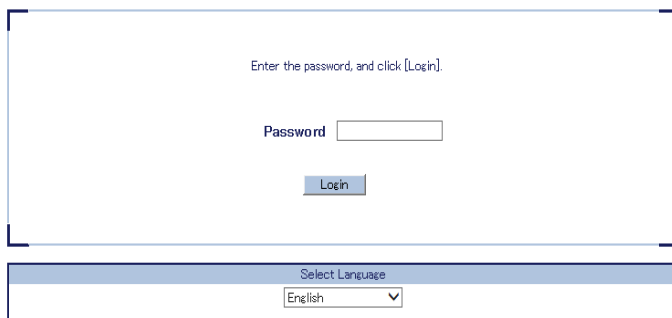

Note

- If the IP address or network operation mode is changed on FBR-100AN/FBR-100 and which does not allow communication from the PC, the login page is not displayed.

Bridge Setting

1. Select **Bridge** for the **Network operation mode**.

Device Configuration	
Name	Value
Host Name	FBR-013125
Wireless Interface	[DISABLE]
Network operation mode	Bridge ▼
Link Speed Port1	AUTO ▼
Link Speed Port2	AUTO ▼

2. Configure each setting.

Name Resolve Protocols Configuration	
Name	Value
DNS Suffix	
DNS Server (Primary)	0.0.0.0
DNS Server (Secondary)	0.0.0.0

Bridge Port	
Interface Configuration	Value
Add to Bridge	<input type="radio"/> All <input checked="" type="radio"/> Wired Only <input type="radio"/> Custom
DHCP Client	DISABLE ▼
IP Address	192.168.3.1
Subnet Mask	255.255.255.0



TIP

- **Add to Bridge** is displayed only for FBR-100AN.
- When **Custom** is selected for **Add to Bridge**, two or more interfaces need to be selected.
- When a wireless LAN is included as an interface to bridge, the wireless setting needs to be configured at **Wireless LAN(STA)**.



Note

- For details on each configuration item, refer to **A-1. List of All Settings**.

3. Check the settings and click **Submit**.





Note

- The entered settings will be cleared if other configuration items are clicked on the menu. To save the entered settings, click **Submit**.
- The new setting will take effect when FBR-100AN/FBR-100 is turned on next time.

- The confirmation message for restart is displayed. To continue the configuration, click the setting item you want to configure from the menu. Click **Restart** to take effect of the new setting when the necessary configuration is finished.

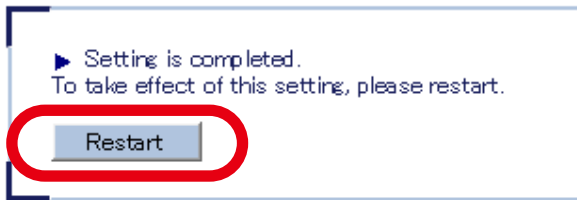

- Do not turn off FBR-100AN/FBR-100 when the restart is in progress.

**Note**

- FBR-100AN/FBR-100 can also be restarted by clicking **Restart** from the configuration menu.

- When the restart is finished and the login page of FBR-100AN/FBR-100 is displayed again, the configuration is completed.

**Note**

- If the IP address or network operation mode is changed on FBR-100AN/FBR-100 and which does not allow communication from the PC, the login page is not displayed.

3-3-2. Detailed Bridge Setting (Only for FBR-100AN)

When there is a device that does not respond to the MAC Address broadcast, edit the address management table.

1. Open your Web browser and access the FBR-100AN's Web page.



Note

- For details on how to access the FBR-100AN's Web page using the Web browser, refer to **3-2-2. Displaying FBR-100AN/FBR-100's Web Page.**

2. Click **General** from the configuration menu.

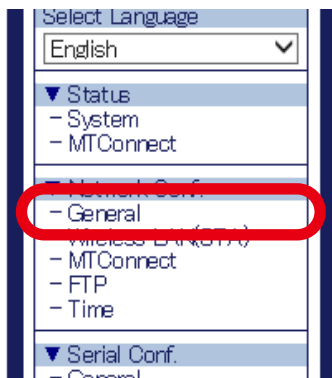

3. Click **Bridge Detailed Configuration.**

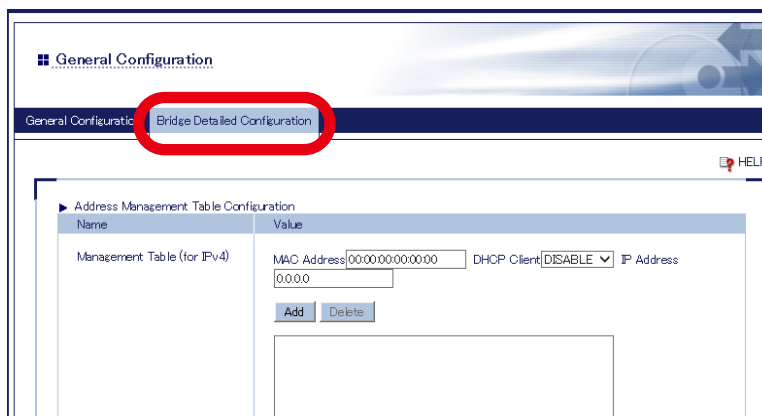

4. Register the device information to the address management table (up to 16 devices).

The screenshot shows the 'General Configuration' web interface. The 'Address Management Table Configuration' section is active. It contains a table with the following data:

Name	Value
Management Table (for IPv4)	MAC Address: 00:00:00:00:00:00 DHCP Client: DISABLE IP Address: 0.0.0.0

Below the table are 'Add' and 'Delete' buttons. A 'Submit' button is located at the bottom right of the configuration area.



- If multiple MAC addresses are set for one IP address, packets cannot be transferred correctly.
- Only IPv4 (Internet Layer), TCP/UDP (Internet Layer), and ARP (Link Layer) of TCP/IP Protocols are guaranteed for transmission. Other protocols are not guaranteed.
- For application-layer protocols, DHCP, FTP, SMPD, HTTP, HTTPS, CNC are guaranteed for communication. Other protocols are not guaranteed.



Note

- For details on each configuration item, refer to **A-1. List of All Settings**.

5. Check the settings and click **Submit**.



Note

- The entered settings will be cleared if other configuration items are clicked on the menu. To save the entered settings, click **Submit**.
- The new setting will take effect when FBR-100AN is turned on next time.

6. The confirmation message for restart is displayed. To continue the configuration, click the setting item you want to configure from the menu. Click **Restart** to take effect of the new setting when the necessary configuration is finished.

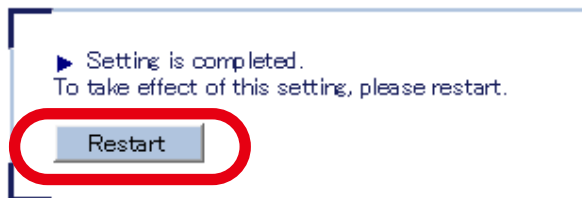

- Do not turn off FBR-100AN when the restart is in progress.



Note

- FBR-100AN can also be restarted by clicking **Restart** from the configuration menu.

7. When the restart is finished and the login page of FBR-100AN is displayed again, the configuration is completed.



Note

- If the IP address or network operation mode is changed on FBR-100AN and which does not allow communication from the PC, the login page is not displayed.

3-4. Using Wireless Station Function (Only for FBR-100AN)

The following explains how to use FBR-100AN as a wireless station.

1. Open your Web browser and access the FBR-100AN's Web page.



- For details on how to access the FBR-100AN's Web page using the Web browser, refer to **3-2-2. Displaying FBR-100AN/FBR-100's Web Page.**

Note

2. Click **Wireless LAN(STA)** from the configuration menu.

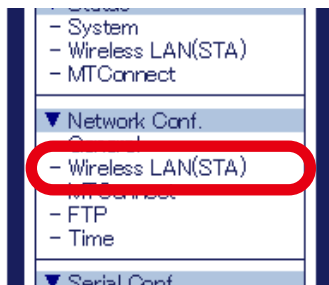

3. The **Easy Configuration** page of **Wireless LAN(STA)** is displayed.

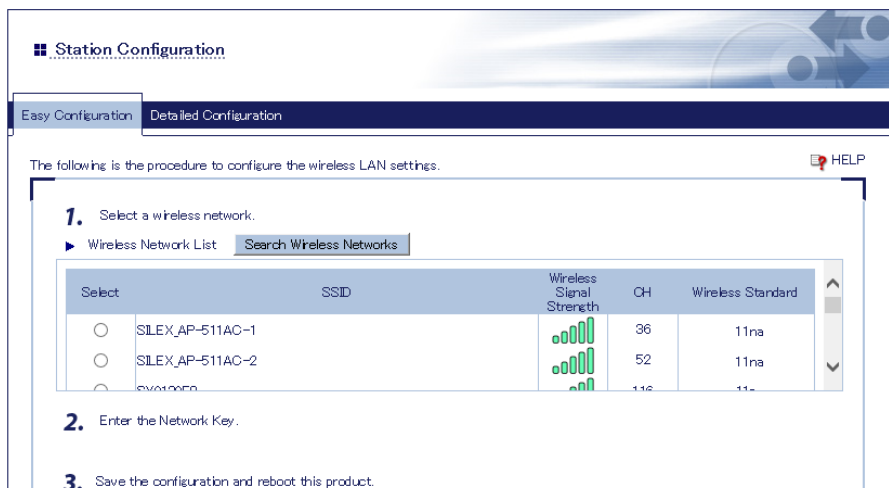

From the following options, select a method to connect to Access Point.

To select the destination device from a list of discovered networks:

Go on to **3-4-1. Connecting Access Point by Using 'Easy Configuration'**.

To specify the destination device to connect:

Go on to **3-4-2. Connecting Access Point by Using 'Detailed Configuration'**.

3-4-1. Connecting Access Point by Using 'Easy Configuration'

From a list of the discovered wireless networks, select one to connect.



TIP

- When the Access Point has one of the following settings, it cannot be connected using the '**Easy Configuration**' feature. Refer to **3-4-2. Connecting Access Point by Using 'Detailed Configuration'** then.
 - WEP key is used and WEP key index of the Access Point is other than 1.
 - Network authentication method is set to Shared, WPA2-EAP or WPA/WPA2-EAP.
 - Stealth function is enabled on the Access Point.

1. Click **Wireless LAN(STA)** from the configuration menu and click **Easy Configuration**.



Note

- When the **Easy Configuration** page is already displayed, this process is not necessary.

2. The **Easy Configuration** page is displayed and wireless networks are detected.

Station Configuration

Easy Configuration Detailed Configuration

The following is the procedure to configure the wireless LAN settings. [HELP](#)

1. Select a wireless network.
 - ▶ Wireless Network List
 - ▶ Searching...
Please wait for a while.
2. Enter the Network Key.
3. Save the configuration and reboot this product.

3. From a list of the discovered wireless networks, select one to connect and then enter the network key.

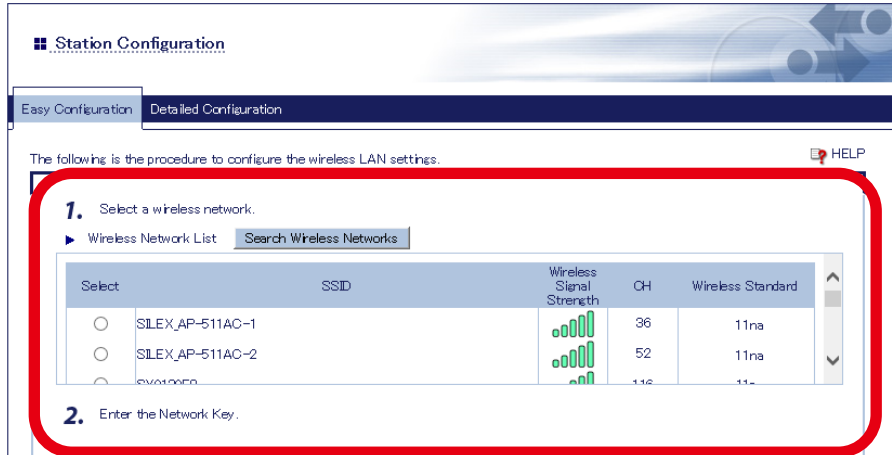

Note

- In the wireless network list, up to 32 Access Points are displayed in the order of higher signal strength.
- When the network key of the Access Point is already registered to FBR-100AN, such Access Point is displayed in the top of the list, regardless of the signal strength.
- To refresh the wireless network list, click **Search Wireless Networks**.
- When the network authentication method of Access Point is set to **WPA-PSK** or **WPA2-PSK**, network authentication and encryption mode of FBR-100AN are set to **WPA/WPA2-PSK** and **AUTO** respectively.

4. Check the settings and click **Submit**.



5. The confirmation message for restart is displayed.
To continue the configuration, click the setting item you want to configure from the menu. Click **Restart** to take effect of the new setting when the necessary configuration is finished.

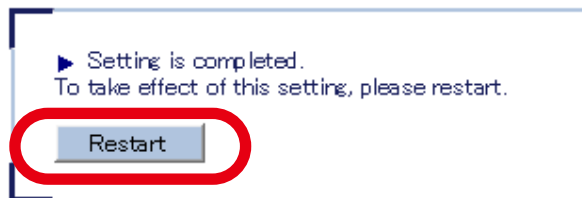

- Do not turn off FBR-100AN when the restart is in progress.



Note

- FBR-100AN can also be restarted by clicking **Restart** from the configuration menu.

6. When the restart is finished and the login page of FBR-100AN is displayed again, the configuration is completed.

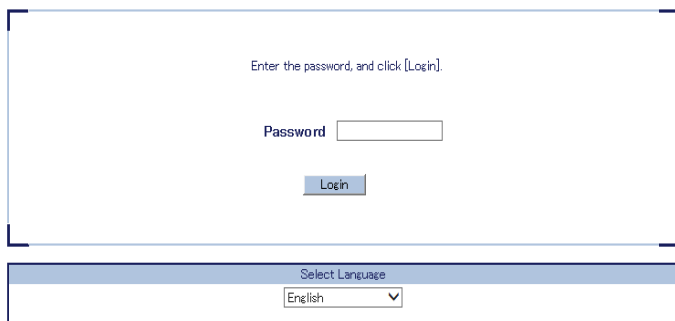

Note

- If the IP address or network operation mode is changed on FBR-100AN and which does not allow communication from the PC, the login page is not displayed.

3-4-2. Connecting Access Point by Using 'Detailed Configuration'

Configure the setting to connect the Access Point in wireless LAN.

1. Click **Wireless LAN(STA)** from the configuration menu and click **Detailed Configuration**.



- When the **Detailed Configuration** page is already displayed, this process is not necessary.

Note

2. In the **Detailed Configuration** page, configure each setting.

Wireless LAN Basic Configuration	
Name	Value
SSID	<input type="text" value="SSID"/>
Network Authentication	Open

WEP Configuration	
Name	Value
WEP	OFF
Key Index	1
WEP Key1	<input type="text"/>
WEP Key2	<input type="text"/>
WEP Key3	<input type="text"/>
WEP Key4	<input type="text"/>



Note

- For details on each configuration item, refer to **A-1. List of All Settings**.
- FBR-100AN supports the IEEE802.1X authentication. For information on the compatible authentication methods and certificates, refer to **IEEE802.1X Authentication**.

3. Check the settings and click **Submit**.



- The entered settings will be cleared if other configuration items are clicked on the menu. To save the entered settings, click **Submit**.

Note • The new setting will take effect when FBR-100AN is turned on next time.

4. The confirmation message for restart is displayed.

To continue the configuration, click the setting item you want to configure from the menu. Click **Restart** to take effect of the new setting when the necessary configuration is finished.

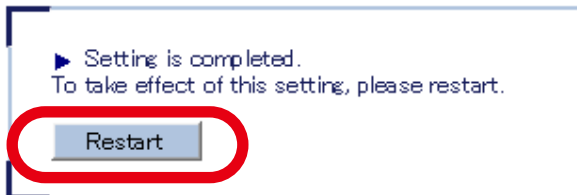

TIP

- Do not turn off FBR-100AN when the restart is in progress.



Note

- FBR-100AN can also be restarted by clicking **Restart** from the configuration menu.

5. When the restart is finished and the login page of FBR-100AN is displayed again, the configuration is completed.



Note

- If the IP address or network operation mode is changed on FBR-100AN and which does not allow communication from the PC, the login page is not displayed.

IEEE802.1X Authentication

FBR-100AN supports the following IEEE802.1X authentication methods.

IEEE802.1X can be used when **Network Authentication** is set to **WPA2-EAP** or **WPA/WPA2-EAP**. To use the authentication method that requires a certificate, the necessary certificate needs to be issued from the authentication agency and be imported to FBR-100AN.

Settings on each authentication mode

The compatible settings on each authentication mode are as follows.
For details, refer to **Appendix A-1. List of All Settings**.

Name	IEEE802.1X Authentication Mode				
	EAP-TLS	EAP-TTLS	PEAP	EAP-FAST	LEAP
EAP User Name	Necessary	Necessary	Necessary	Necessary	Necessary
EAP Password	–	Necessary	Necessary	Necessary	Necessary
Inner Authentication Method	–	Necessary	Necessary	–	–
Client Certificate Password	Necessary	–	–	–	–
Client Certificate	Necessary	–	–	–	–
Server Authentication	Optional	Optional	Optional	–	–
CA Certificate	Optional	Optional	Optional	–	–
PAC Auto-distribution	–	–	–	Optional	–
PAC File	–	–	–	Optional	–

Name	Details
EAP User Name	This is an ID and password that are used when the server identifies the client.
EAP Password	
Inner Authentication Method	Specify the authentication protocol to use. For PEAP, MSCHAPv2 is used.
Client Certificate Password	Use this to check the client reliability. To retrieve a secret key from the client certificate, a password is required.
Client Certificate	
Server Authentication	Enable/Disable the reliability check of the server. When ON is selected, CA certificate is required to verify the server certificate.
CA Certificate	This is a CA certificate to authenticate the server.
PAC Auto-distribution	Enable/Disable the automatic PAC distribution. When OFF is selected, the PAC file is required that is generated by the server.
PAC File	This is a file used for manual provisioning. The file is issued from the RADIUS server. When a password is set to the PAC file, it cannot be used.



- Please create the client certificate and the CA certificate separately. FBR-100AN does not support the certificate composed of multiple certificate files.

Certificate Standard

The following certificates are supported:

Certificate	Item	Compatible standards
Client certificate	X509 certificate version	v3
	Public key algorithm	RSA
	Public key size	512bit, 1024bit, 2048bit
	Signature algorithm	SHA1/SHA2 (SHA-224, SHA-256, SHA-384, SHA-512) withRSA MD5withRSA
	X509v3 extended key usage	Client authentication (1.3.6.1.5.5.7.3.2)
CA certificate	Public key algorithm	RSA
	Public key size	512bit, 1024bit, 2048bit
	Signature algorithm	SHA1/SHA2 (SHA-224, SHA-256, SHA-384, SHA-512) withRSA MD5withRSA

Certificate Saving Format

The following saving formats are supported:

Certificate	Compatible standards
Client certificate	pfx * This is a format that includes a secret key of the certificate.
CA Certificate	PEM (A text format in which DER is BASE64 encoded.)

IEEE802.1X Connection Setting

When **Network Authentication** is **WPA2-EAP** or **WPA/WPA2-EAP**, it is possible to enable/disable a filter for the devices that are registered to the address management table.

When the filter is disabled, the communication data is bridged to wireless network even if the connected device is not registered to the address management table.

In that case, the device authentication feature of IEEE802.1X cannot be used.

3-5. Using AMC Manager® to Configure

The FBR-100AN/FBR-100 settings can be configured using AMC Manager®. For details on how to use AMC Manager®, see the user's manual of AMC Manager®.

AMC Manager® can be used to configure the following settings.

- Password
- Default Gateway
- Link Speed Port 1/2
- DHCP Client
- IP Address
- Subnet Mask

DHCP Client, IP Address and Subnet Mask can be set at LAN Port1 / LAN Port2 / WLAN Port / Bridge Port.



Note

- For details on each configuration item, refer to **A-1. List of All Settings**.

3-6. Installing and Using FBR-100AN/FBR-100

After the configuration is finished, install and fix FBR-100AN/FBR-100 in the location of use. For use in wired LAN, connect FBR-100AN/FBR-100 to the network using a LAN cable before turning on it. To fix FBR-100AN/FBR-100 to the location of use, you can use either the mounting stays on the product case or the DIN rail mounting plate (commercially available).

Fixing DIN rail mounting plate to FBR-100AN/FBR-100

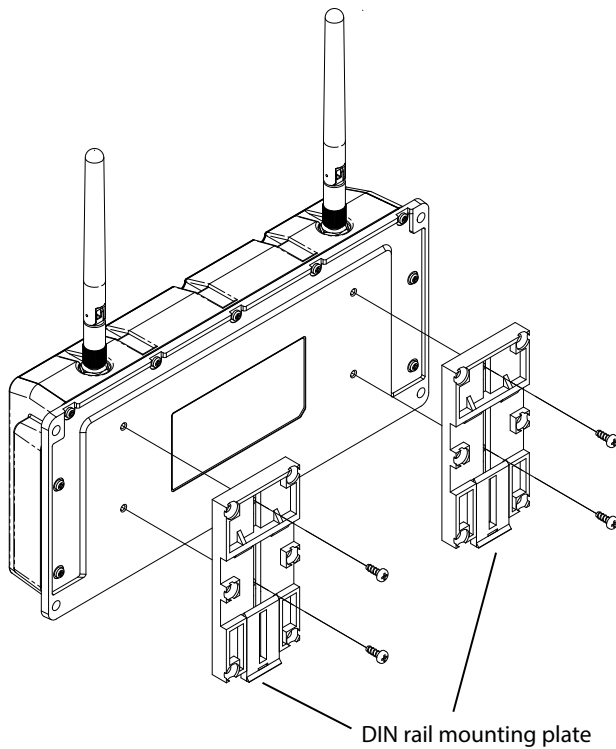

Fixing DIN rail mounting plate to DIN rail

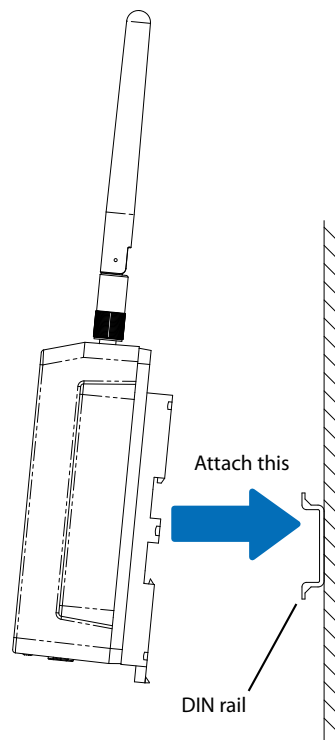

Note

- DIN rail and DIN rail mounting plate are not contained in the product package. They need to be purchased separately.
- Recommended DIN rail mounting plate : TAKACHI DRP5-9W
- For the mounting screw, tapping screw (for plastic) is recommended.
 - Nominal diameter: 3mm
 - Nominal length: 10-13mm

4. List of Functions

This chapter explains the FBR-100AN/FBR-100 functions.

4-1. Showing System Status

The system status shows the operating status of FBR-100AN/FBR-100.

1. Open your Web browser and access the FBR-100AN/FBR-100's Web page.



- For details on how to access the FBR-100AN/FBR-100's Web page using the Web browser, refer to **3-2-2. Displaying FBR-100AN/FBR-100's Web Page.**

Note

2. Click **System** from the configuration menu.

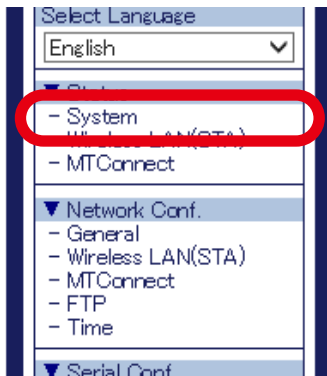

3. The **System Status** page is displayed.

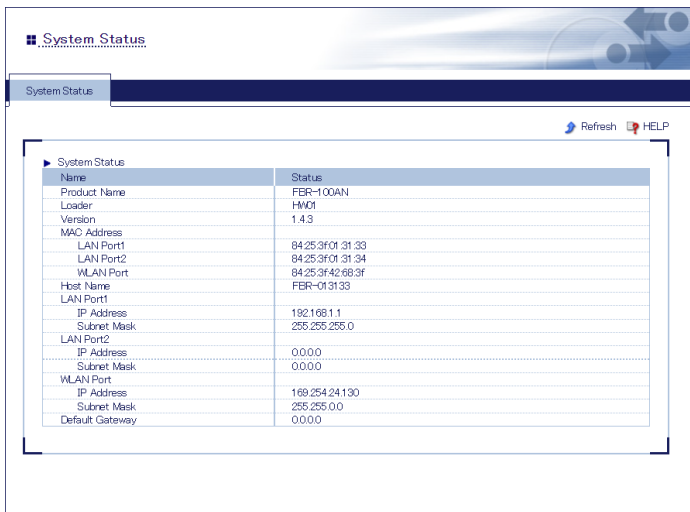

4-2. Showing Wireless LAN(STA) Status(Only for FBR-100AN)

Wireless LAN(STA) status shows the setting of wireless station.

1. Open your Web browser and access the FBR-100AN's Web page.



- For details on how to access the FBR-100AN's Web page using the Web browser, refer to **3-2-2. Displaying FBR-100AN/FBR-100's Web Page.**

Note • In the configuration menu, **Wireless LAN(STA)** under **Status** is not displayed when a wireless LAN interface is not enabled.

2. Click **Wireless LAN(STA)** from the configuration menu.

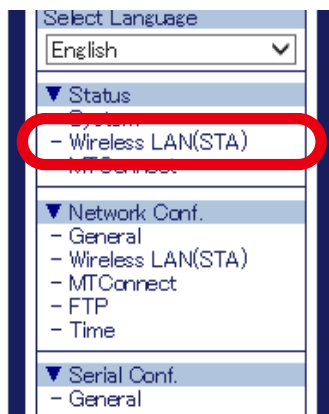

3. The **Station Status** page is displayed.

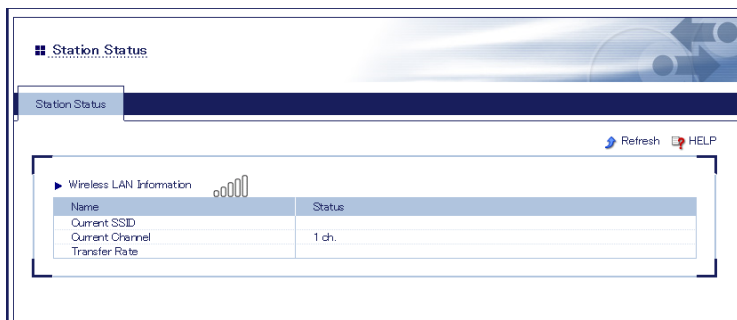

4-3. Showing MTConnect Status

MTConnect status shows the MTConnect setting.

1. Open your Web browser and access the FBR-100AN/FBR-100's Web page.



Note

- For details on how to access the FBR-100AN/FBR-100's Web page using the Web browser, refer to **3-2-2. Displaying FBR-100AN/FBR-100's Web Page.**

2. Click **MTConnect** from the configuration menu.

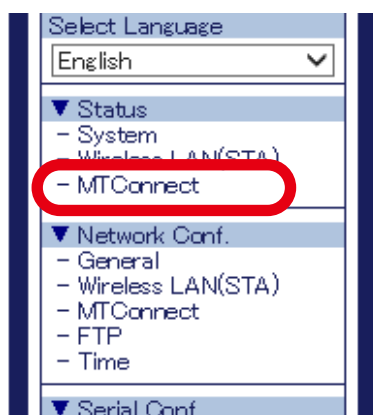

3. The **MTConnect Status** page is displayed.



Note

- When the CNC device is connected, series name / CNC system number / PMC system number of that CNC device are displayed.
- When MTConnect Mode is set to **agent & adapter** or **agent**, a link to the MTConnect page is displayed. If the link is clicked, the MTConnect page will show up in a separate window at which you can easily check the collected data. For details, refer to "**current**" at **List of HTTP Requests of 4-4-3. Checking Collected Machine Tool Data.**
- To show the AirGRID® status, enable the AirGRID® link feature as described at **4-4-4. Collecting Information of Stack Tower Light Using AirGRID®.** The WDR's connection status and WDT's MAC address will be displayed.
- The error code is displayed if an error occurs as a result of connection. Refer to **A-2. List of Error Codes** for details on how to handle it. Also, if a link is clicked, the help page is displayed.

4-4. Using MTConnect

The following explains how to collect the CNC data.

4-4-1. What is MTConnect?

- MTConnect is the communication protocol for machine tools, which is standardized by the MTConnect Institution.
- MTConnect uses the open communication interfaces (HTTP/XML). It only supports reading the values from the operating monitor of machine tools and does not support writing the values.
- As FBR-100AN/FBR-100 has the Agent and Adapter functions of the MTConnect server, CNC data can be collected by the following methods.
 - Use the MTConnect client compatible software.
 - Use the MTConnect Agent compatible software.
 - Connect to the CNC machine tool that has the MTConnect Adapter and then use the MTConnect client compatible software.

**Note**

- FBR-100AN/FBR-100 does not include the MTConnect client software. Please purchase it separately (e.g. MTLINKi of FANUC, etc.). For evaluation of FBR-100AN/FBR-100, a free sample client software can be downloaded from our website.

Agent and Adapter

FBR-100AN/FBR-100 has both MTConnect Agent and Adapter features and can receive the data in XML format or SHDR format (the format with vertical separation lines).

- Agent
Collects the data of Adapter.
FBR-100AN/FBR-100 retrieves the data from Adapter and then replies in XML format data, when it is accessed by the client software.
- Adapter
Collects the data of machine tools.
FBR-100AN/FBR-100 replies with SHDR format data (the format with vertical separation lines), when it is accessed by the client software.

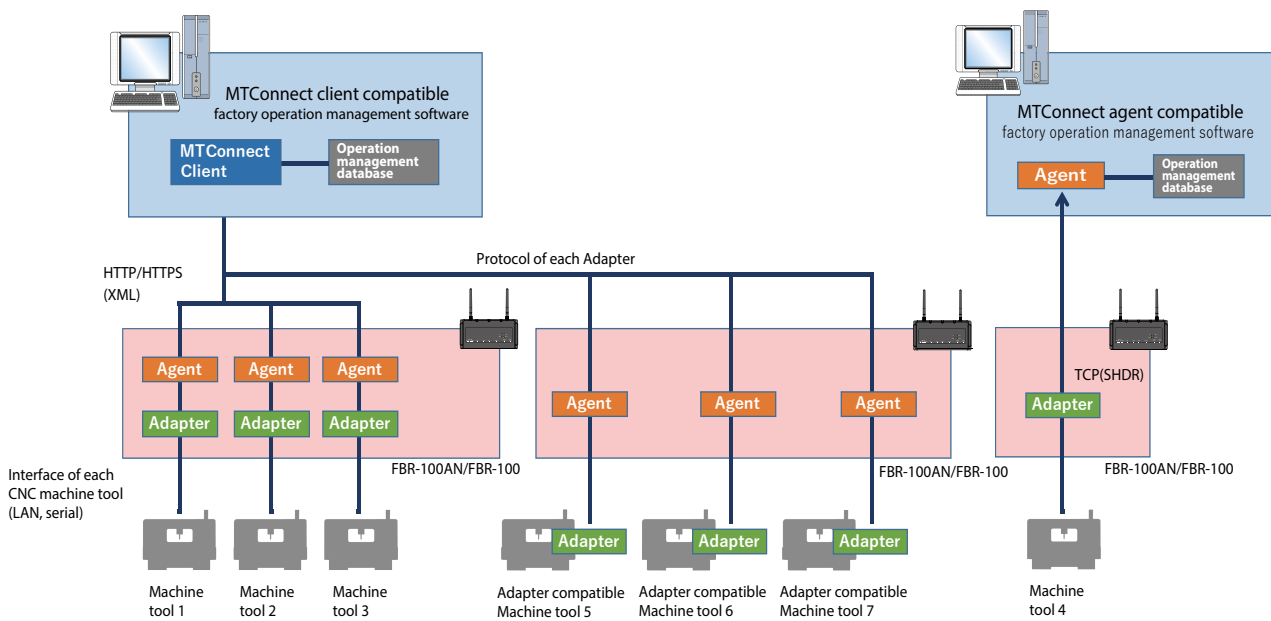

- The operating information of maximum 3 CNC machine tools can be retrieved by FBR-100AN/FBR-100. When the maximum 3 CNC machine tools are used, a part of the reading function is restricted.

Data Collection Method

There are 5 methods of collecting the machine tool data.

Network

The data of each point is collected individually based on the default point or custom point settings configured at the Web page of FBR-100AN/FBR-100.



Note

- When the firmware version of FBR-100AN/FBR-100 is 1.4.1 or lower, it is also possible to use the point file that is created by the point file creation tool. It can be imported from the Web page of FBR-100AN/FBR-100.

DPRNT

DPRNT specification data is collected at once from a serial (RS-232C).

agent

Agent mode is on. The data is collected from the adapter.

AirGRID®

Only information of the stack tower light is collected using the wireless communication system AirGRID® developed by PATLITE Corporation.



TIP

- WDT supports AirGRID® only when it is operating in the immediate transmission mode.

Glossary

Term	Description
Point file	This is the configuration file to specify the information of machine tools as a point and transfer it by MTConnect.
Devices.xml file	Devices.xml is used for agent mode collection. It is a file to define the machine tool configuration as MTConnect.

4-4-2. MTConnect Setting

The following explains how to configure the MTConnect setting.

MTConnect setting

1. Open your Web browser and access the FBR-100AN/FBR-100's Web page.



- For details on how to access the FBR-100AN/FBR-100's Web page using the Web browser, refer to **3-2-2. Displaying FBR-100AN/FBR-100's Web Page.**

Note

2. Click **MTConnect** from the configuration menu.

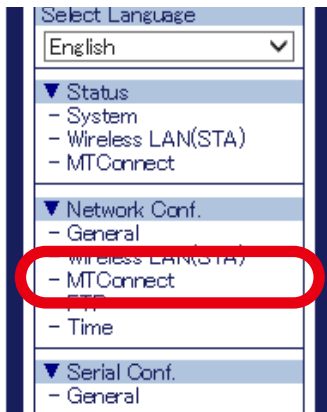

3. The **MTConnect Configuration** page is displayed. Configure each setting.

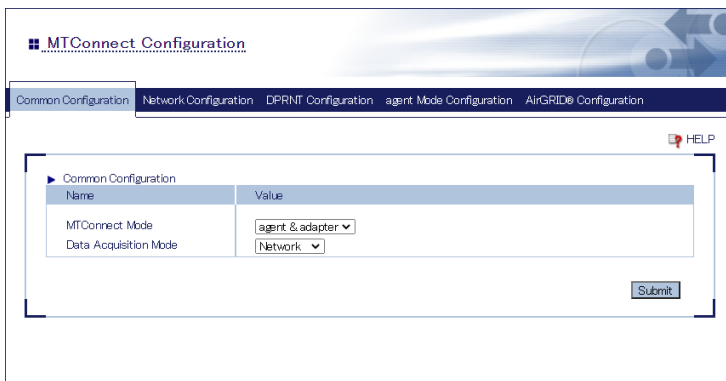

4. Check the settings and click **Submit**.



Note

- The entered settings will be cleared if other configuration items are clicked on the menu. To save the entered settings, click **Submit**.

5. Configure the settings appropriately for **Data Acquisition Mode** you have selected.

- For network collection
Click **Network Configuration**.
- For DPRNT collection
Click **DPRNT Configuration**.
- For agent mode collection
Click **agent Mode Configuration**.
- For AirGRID® collection
Click **AirGRID® Configuration**.

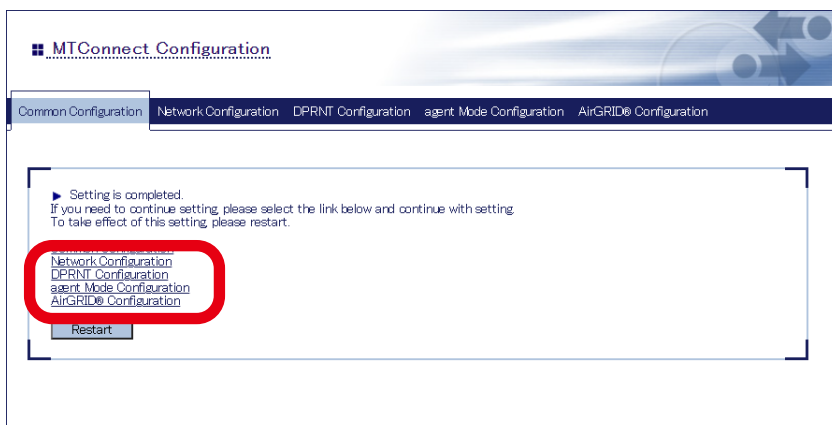

6. Configure each setting in the displayed page.

Network Configuration

DPRNT Configuration

agent Mode Configuration

AirGRID® Configuration

WDT	MAC Address	MTConnect Port(HTTP)	MTConnect Port(HTTPS)
WDT1	0000000000000000	5000	5443
WDT2	0000000000000000	5001	5444
WDT3	0000000000000000	5002	5445
WDT4	0000000000000000	5003	5446
WDT5	0000000000000000	5004	5447
WDT6	0000000000000000	5005	5448
WDT7	0000000000000000	5006	5449
WDT8	0000000000000000	5007	5450



Note

- For details on each configuration item, refer to **A-1. List of All Settings**.

7. Check the settings and click **Submit**.



Note

- The entered settings will be cleared if other configuration items are clicked on the menu. To save the entered settings, click **Submit**.

8. The confirmation message for restart is displayed.
To continue the configuration, click a link to the configuration.
Click **Restart** to take effect of the new setting when the necessary configuration is finished.



TIP

- Do not turn off FBR-100AN/FBR-100 when the restart is in progress.



Note

- FBR-100AN/FBR-100 can also be restarted by clicking **Restart** from the configuration menu.

9. When the restart is finished and the login page of FBR-100AN/FBR-100 is displayed again, the configuration is completed.

Network Collection Setting

The following explains how to set the target points to collect using the Web page of FBR-100AN/FBR-100.

1. Open your Web browser and access the FBR-100AN/FBR-100's Web page.



Note

- For details on how to access the FBR-100AN/FBR-100's Web page using the Web browser, refer to **3-2-2. Displaying FBR-100AN/FBR-100's Web Page.**

2. Click **MTConnect** from the configuration menu.

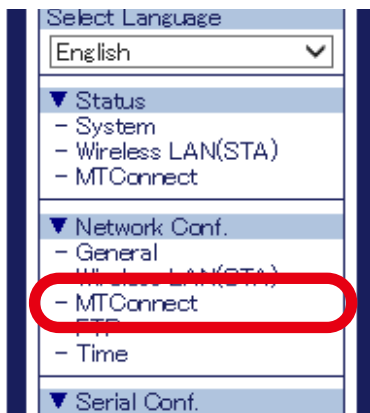

3. The **MTConnect Configuration** page is displayed. Select **Network Configuration**.



4. The network configuration page is displayed.
Follow one of the steps below to set the point to collect.

The screenshot shows the 'MTConnect Configuration' interface with the 'Network Configuration' tab selected. It displays two configuration sections: 'Network Configuration 1' and 'Network Configuration 2'. Each section has a table with 'Name' and 'Value' columns.

Name	Value
MTConnect Port(HTTP)	5000
MTConnect Port(HTTPS)	5443
CNC ID	FBR-01312D-01
CNC IP Address	172.25.70.203
CNC Port	7193
Default Point	→ Default Point Configuration
Custom Point	→ Custom Point Configuration
Point file (C# in ver.1.4.1 or earlier)	Choose File No file chosen Import

Name	Value
MTConnect Port(HTTP)	5001
MTConnect Port(HTTPS)	5444
CNC ID	FBR-01312D-02
CNC IP Address	0.0.0.0
CNC Port	8193
Default Point	→ Default Point Configuration
Custom Point	→ Custom Point Configuration
Point file	Choose File No file chosen Import

Default Point Configuration

To use the default point, select **Default Point Configuration** at **Network Configuration 1-3**.

This screenshot is identical to the previous one, but a red circle highlights the 'Default Point Configuration' option in the 'Default Point' row of 'Network Configuration 1'.

When the default point setting page is displayed, set whether to collect or not and the collection interval for each item, and click **Submit**.



- **Custom Macro Collective Configuration, PMC Collective Configuration, Tool Offset Collective Configuration** are only on **Network Configuration1**.



Note

- Clicking **[All ON]/[All OFF]** will select **ON/OFF** for all items at the default point configuration.

Custom Point Configuration

To use the custom point, select **Custom Point Configuration** at **Network Configuration 1-3**.

The screenshot shows the MTConnect Configuration interface with the 'Network Configuration' tab selected. It displays two configuration sections: 'Network Configuration 1' and 'Network Configuration 2'. In 'Network Configuration 1', the 'Custom Point' dropdown menu is highlighted with a red circle and shows the option 'Custom Point Configuration'. Other fields include MTConnect Port (HTTP), MTConnect Port (HTTPS), CNC ID, CNC IP Address, CNC Port, Default Point, and Point file. 'Network Configuration 2' has similar fields but with different values and a 'Default Point Configuration' option in the dropdown.

When the custom point setting page is displayed, set each item at **Custom Point Configuration**.

The screenshot shows the 'Custom Point Configuration' page for 'Network Configuration 1'. It features a table for configuration items:

Name	Value
CNC path	1
PMD path	1
DCS Ladder	DISABLE

Below the table is a 'Custom Point List' section with a warning: 'If you change the page without clicking "Submit," the input data will be discarded'. It includes an 'Add New Point' button and a table with columns for 'Point Name' and 'Operation'. A 'Submit' button is located at the bottom of the page.

Click **Add New Point** at **Custom Point List**, configure each setting for point to add, and click **Add**. Repeat this for as many points as you want to add.

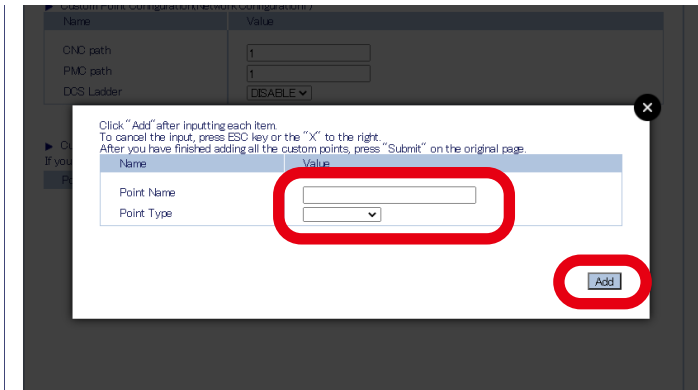

When the point has been added, click **Submit**.

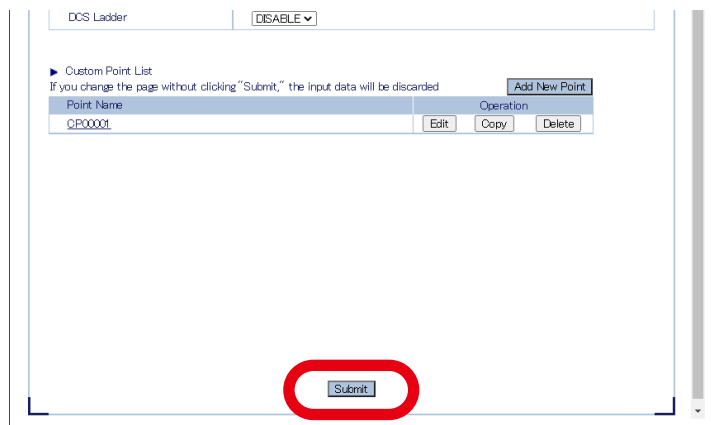

- Up to 130 custom points can be added.

Note

5. Check the settings and click **Submit**.



- The entered settings will be cleared if other configuration items are clicked on the menu. To save the entered settings, click **Submit**.

Note

6. The confirmation message for restart is displayed.
To continue the configuration, click a link to the configuration.
Click **Restart** to take effect of the new setting when the necessary configuration is finished.

**TIP**

- Do not turn off FBR-100AN/FBR-100 when the restart is in progress.

**Note**

- FBR-100AN/FBR-100 can also be restarted by clicking **Restart** from the configuration menu.

7. When the restart is finished and the login page of FBR-100AN/FBR-100 is displayed again, the configuration is completed.

4-4-3. Checking Collected Machine Tool Data

The collected CNC device data can be checked from the MTConnect Client tool or Web browser.

List of HTTP Requests

FBR-100AN/FBR-100 supports the following HTTP requests.

Command	Description	Input Format
probe	Returns all device information of CNC device (1 device).	Format: http://IP address:port number/probe (Example) - Returns all device information. http://192.168.1.1:5000/probe
current	Requests for the latest values of CNC device. The location information and rotation speed can be retrieved.	Format: http://IP address:port number/current (Example) - Returns the latest data. http://192.168.1.1:5000/current - Returns data of the specified sequence number. http://192.168.1.1:5000/current?at=1232
sample	Requests for the history information by the specified sequence number of CNC device. When the count is not specified, the newest 100 history items are returned.	Format: http://IP address:port number/sample (Example) - Returns the latest 100 history items. http://192.168.1.1:5000/sample - Returns the history items with the sequence number 50-100. http://192.168.1.1:5000/sample?from=50&count=100



• "(Double-quote) and space require URL encoding.

The details of the error are as follows.

Error Code	Description
NO_DEVICE	The device specified in the URI could not be found.
OUT_OF_RANGE	The sequence number was beyond the end of the buffer.
INVALID_XPATH	The XPath could not be parsed. Invalid syntax or XPath did not match any valid elements in the document.
UNSUPPORTED	A valid request was provided, but the Agent does not support the feature or request type.

Sample of MTConnect Client Utility

The sample of MTConnect client utility can be downloaded from the Silex Technology's website.

1. Access the website below on your PC.

<https://www.silextechnology.com/>

2. Go to the support page and download the sample of MTConnect client utility.

4-4-4. Collecting Information of Stack Tower Light Using AirGRID®

The information of stack tower light can be collected using the wireless communication system AirGRID® developed by PATLITE Corporation. The AirGRID® link function can be selected from the following configuration modes of FBR-100AN/FBR-100.

Integrated collection mode:

From the Web page of FBR-100AN/FBR-100, configure the data collection setting at **AirGRID® Migration Configuration** in the **Network Configuration** page.

- Up to 3 machine tools and AirGRID® transmitters are supported.
- CNC device and stack tower light are displayed as machine tool information of one device.
- The upper system monitors two types of information for each machine.

Single collection mode:

From the Web page of FBR-100AN/FBR-100, select **AirGRID®** for **Data Acquisition Mode**.

- Up to 30 AirGRID® transmitters can be used.
- Only information of the stack tower light is collected and transferred.
- Old machines can be connected to the upper system that supports MTConnect.

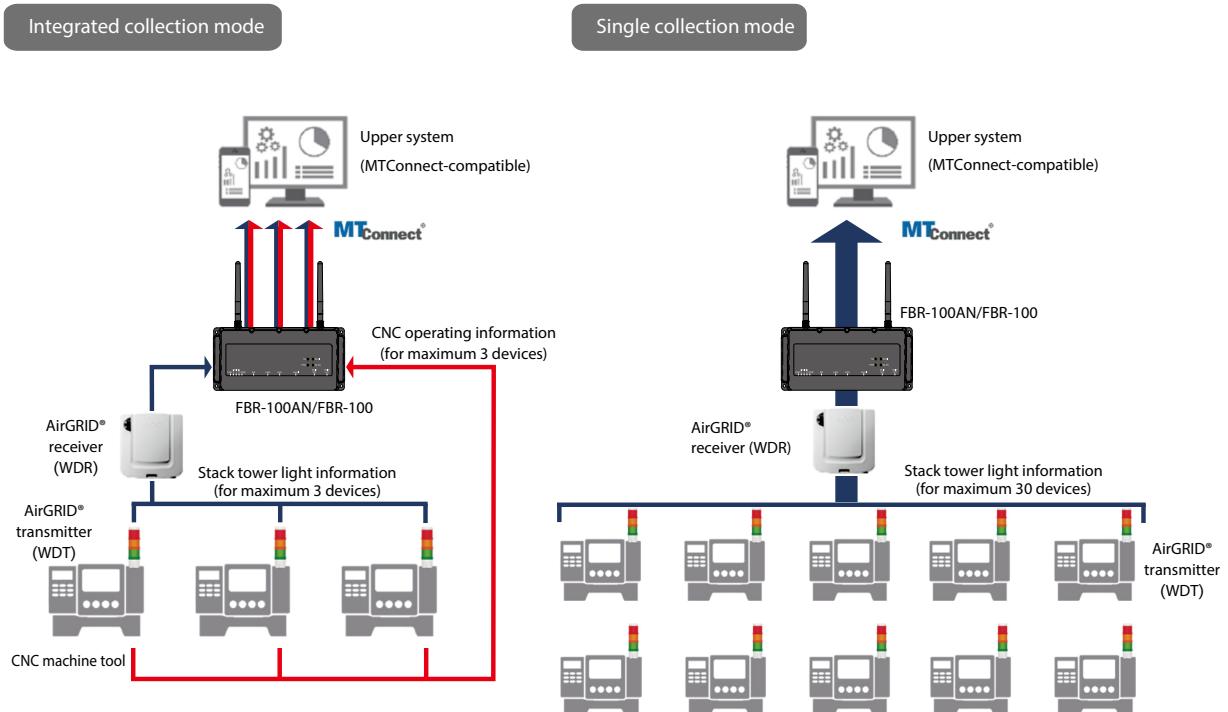

Note

- For details on how to access the FBR-100AN/FBR-100's Web page using the Web browser, refer to **3-2-2. Displaying FBR-100AN/FBR-100's Web Page.**
- For details on each configuration item, refer to **A-1. List of All Settings.**

4-5. FTP Setting

The following explains how to configure the FTP setting.

1. Open your Web browser and access the FBR-100AN/FBR-100's Web page.



- For details on how to access the FBR-100AN/FBR-100's Web page using the Web browser, refer to **3-2-2. Displaying FBR-100AN/FBR-100's Web Page.**

Note

2. Click **FTP** from the configuration menu.

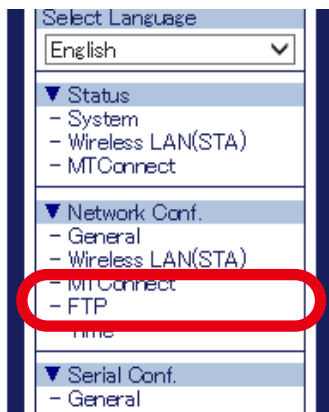

3. The **FTP Configuration** page is displayed. Configure each setting.

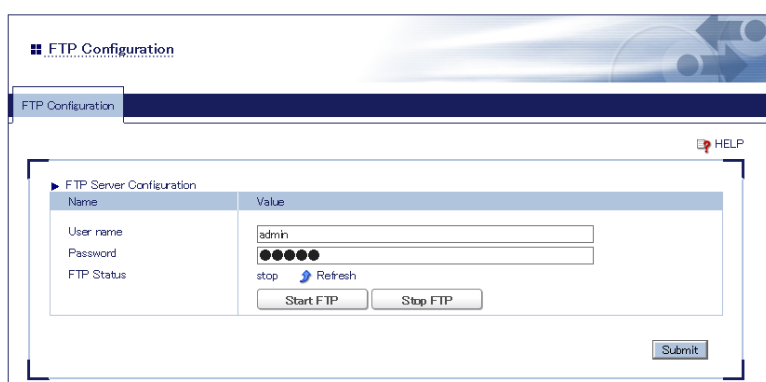

- For details on each configuration item, refer to **A-1. List of All Settings.**

Note

4. Clicking **Start FTP** starts the FTP server function, and clicking **Stop FTP** stops the FTP server function. The directory of the FTP server is as follows.

Directory	Description
FTP/emmc_ftp	After the files are written to the emmc_ftp directory, they are saved on emmc of FBR-100AN/FBR-100. Up to 1.2GByte data can be saved.
FTP/ram_ftp	After the files are written to the ram_ftp directory, they are saved on the RAM of FBR-100AN/FBR-100. The files are deleted when FBR-100AN/FBR-100 is turned off or restarted. Up to 120 MByte data can be saved.



- It is impossible to write the files directly to the FTP directory.

5. Check the settings and click **Submit**.

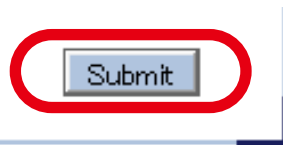

- The entered settings will be cleared if other configuration items are clicked on the menu. To save the entered settings, click **Submit**.

4-6. Time Setting

If the time setting is configured, FBR-100AN/FBR-100 synchronizes with the NTP server to get the time information when it is turned on. It is also possible to configure the time setting manually.

1. Open your Web browser and access the FBR-100AN/FBR-100's Web page.



Note

- For details on how to access the FBR-100AN/FBR-100's Web page using the Web browser, refer to **3-2-2. Displaying FBR-100AN/FBR-100's Web Page.**

2. Click **Time** from the configuration menu.

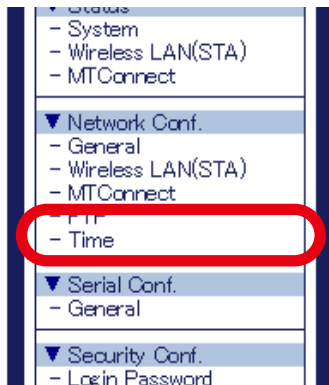

3. The **Time Configuration** page is displayed. Configure each setting.

The screenshot shows the 'Time Configuration' web page with the following sections:

- Date**

Name	Value
Current Local Time (YYYY/MM/DD H:mm:ss)	1970/01/01 09:31:57 (GMT +0900)
- Timezone Configuration**

Name	Value
Time Zone	+9 : 00
- Date and Time Configuration**

Name	Value
NTP Function	DISABLE
NTP Server	
Manual Configuration (YYYY/MM/DD H:mm)	2019 / 01 / 01 00 : 31

A 'Submit' button is located at the bottom right of the configuration area.

**Note**

- For details on each configuration item, refer to **A-1. List of All Settings**.

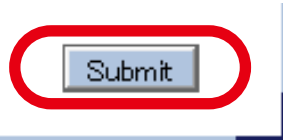
4. Check the settings and click **Submit**.**Note**

- The entered settings will be cleared if other configuration items are clicked on the menu. To save the entered settings, click **Submit**.
- The new setting will take effect when FBR-100AN/FBR-100 is turned on next time.

5. The confirmation message for restart is displayed.

To continue the configuration, click the setting item you want to configure from the menu. Click **Restart** to take effect of the new setting when the necessary configuration is finished.

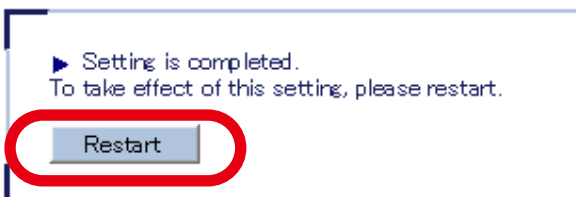
**TIP**

- Do not turn off FBR-100AN/FBR-100 when the restart is in progress.

**Note**

- FBR-100AN/FBR-100 can also be restarted by clicking **Restart** from the configuration menu.

6. When the restart is finished and the login page of FBR-100AN/FBR-100 is displayed again, the configuration is completed.

4-7. Serial Setting

The serial communication setting can be configured.

1. Open your Web browser and access the FBR-100AN/FBR-100's Web page.



Note

- For details on how to access the FBR-100AN/FBR-100's Web page using the Web browser, refer to **3-2-2. Displaying FBR-100AN/FBR-100's Web Page.**

2. Click **General** from the configuration menu.

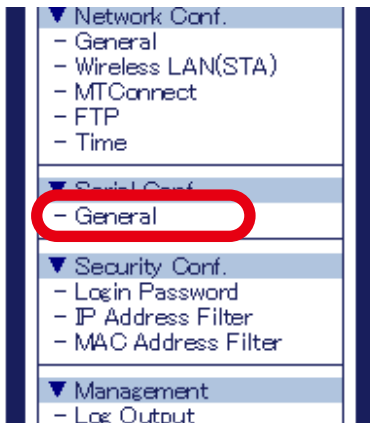

3. The **General Configuration** page is displayed. Configure each setting.

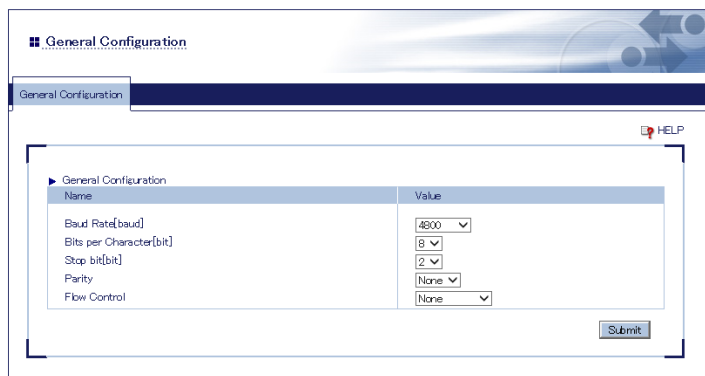

Note

- For details on each configuration item, refer to **A-1. List of All Settings.**

4. Check the settings and click **Submit**.



- The entered settings will be cleared if other configuration items are clicked on the menu. To save the entered settings, click **Submit**.

Note

- The new setting will take effect when FBR-100AN/FBR-100 is turned on next time.

5. The confirmation message for restart is displayed.

To continue the configuration, click the setting item you want to configure from the menu. Click **Restart** to take effect of the new setting when the necessary configuration is finished.

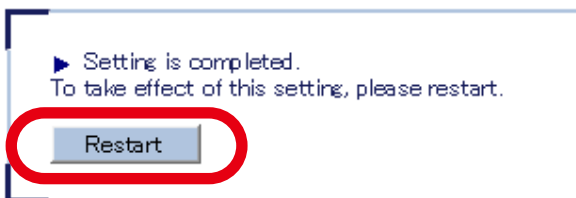

TIP

- Do not turn off FBR-100AN/FBR-100 when the restart is in progress.



Note

- FBR-100AN/FBR-100 can also be restarted by clicking **Restart** from the configuration menu.

6. When the restart is finished and the login page of FBR-100AN/FBR-100 is displayed again, the configuration is completed.

4-8. Login Password Change

The following explains how to change the login password.

1. Open your Web browser and access the FBR-100AN/FBR-100's Web page.



Note

- For details on how to access the FBR-100AN/FBR-100's Web page using the Web browser, refer to **3-2-2. Displaying FBR-100AN/FBR-100's Web Page.**

2. Click **Login Password** from the configuration menu.

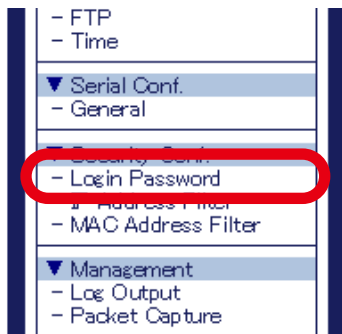

3. The **Login Password Configuration** page is displayed. Configure the new password.

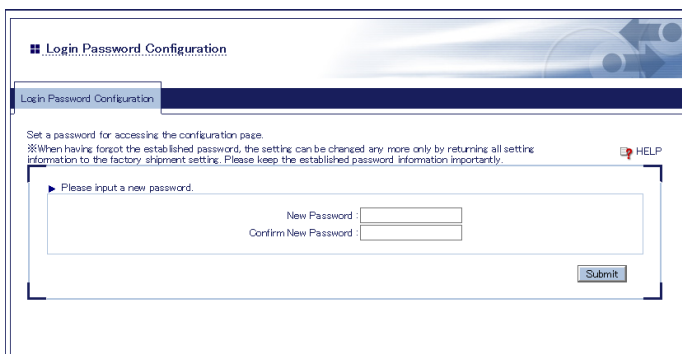

Note

- For details on each configuration item, refer to **A-1. List of All Settings.**

4. Check the settings and click **Submit**.

**Note**

- The entered settings will be cleared if other configuration items are clicked on the menu.
To save the entered settings, click **Submit**.
- The new setting will take effect when FBR-100AN/FBR-100 is turned on next time.

5. The confirmation message for restart is displayed.

To continue the configuration, click the setting item you want to configure from the menu. Click **Restart** to take effect of the new setting when the necessary configuration is finished.

**TIP**

- Do not turn off FBR-100AN/FBR-100 when the restart is in progress.

**Note**

- FBR-100AN/FBR-100 can also be restarted by clicking **Restart** from the configuration menu.

6. When the restart is finished and the login page of FBR-100AN/FBR-100 is displayed again, the configuration is completed.

4-9. IP Address Filter

By registering the IP address filter, access to FBR-100AN/FBR-100 from the specified device can be restricted.

Up to 20 addresses can be registered. For each range of IP address, you can set "ALLOW" to allow access from or "DENY" to deny access from.



- If this function is used, the communication speed may slow down as the network communication is monitored.
- It is possible to use this function for both wired LAN and wireless LAN (only for FBR-100AN).
- Access to the bridged device is not filtered.

1. Open your Web browser and access the FBR-100AN/FBR-100's Web page.



Note

- For details on how to access the FBR-100AN/FBR-100's Web page using the Web browser, refer to **3-2-2. Displaying FBR-100AN/FBR-100's Web Page.**

2. Click **IP Address Filter** from the configuration menu.

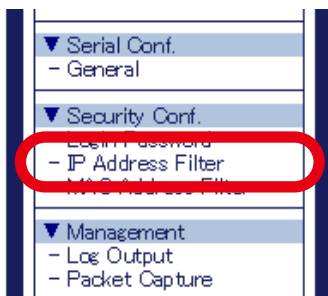

3. The **IP Address Filter Configuration** page is displayed.

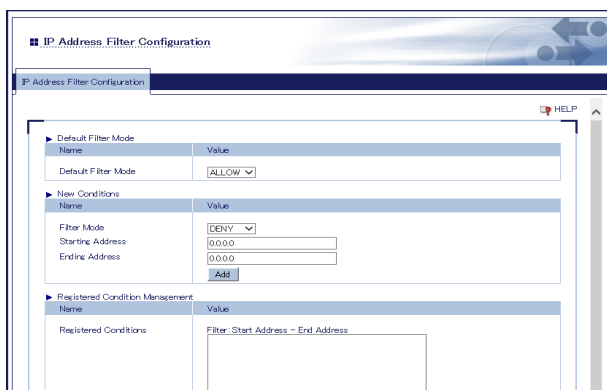

Default Filter Mode

Configure the access control setting for all IP addresses (**ALLOW/DENY**).

When **Default Filter Mode** is set to **ALLOW**, access is allowed from all IP addresses.

When it is set to **DENY**, access from all IP addresses is denied.

Default Filter Mode is used with **Filter Mode**.

If **Default Filter Mode** is set to **DENY**, FBR-100AN/FBR-100 can be accessed only from the devices whose address range is set to **ALLOW** at **Filter Mode**.

Adding Filter Conditions

Select the filter mode at **Filter Mode**, enter the address to **Starting Address** and **Ending Address** to specify the address range, and click **Add**.

Once the filter conditions are registered, it is displayed at **Registered Conditions**.



- If **Default Filter Mode** is set to **DENY** and no IP address is registered, this setting is invalidated and access from all IP addresses is allowed.

Note • For details on each configuration item, refer to **A-1. List of All Settings**.

Deleting Filter Conditions

Select the condition to remove from **Registered Conditions** and click **Delete**.

Changing Priority of Conditions to Use

Select the condition to change the priority and click [↑] button or [↓] button to make the priority of that condition higher or lower.

4. Check the settings and click **Submit**.

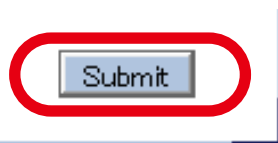

- The entered settings will be cleared if other configuration items are clicked on the menu. To save the entered settings, click **Submit**.

Note • The new setting will take effect when FBR-100AN/FBR-100 is turned on next time.

- 5.** The confirmation message for restart is displayed.
To continue the configuration, click the setting item you want to configure from the menu. Click **Restart** to take effect of the new setting when the necessary configuration is finished.

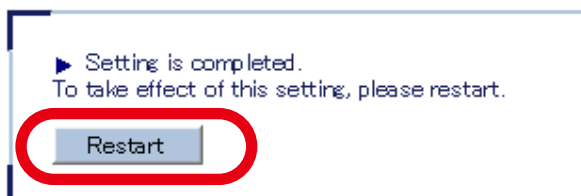

TIP

- Do not turn off FBR-100AN/FBR-100 when the restart is in progress.



Note

- FBR-100AN/FBR-100 can also be restarted by clicking **Restart** from the configuration menu.

- 6.** When the restart is finished and the login page of FBR-100AN/FBR-100 is displayed again, the configuration is completed.



Note

- If the IP address or network operation mode is changed on FBR-100AN/FBR-100 and which does not allow communication from the PC, the login page is not displayed.

4-10. MAC Address Filter

By registering the MAC Address filter, access to FBR-100AN/FBR-100 from the specified device can be restricted. Up to 20 addresses can be registered. For each range of MAC address, you can set "ALLOW" to allow access from or "DENY" to deny access from.



- If this function is used, the communication speed may slow down as the network communication is monitored.
- It is possible to use this function for both wired LAN and wireless LAN (only for FBR-100AN).
- Access to the bridged device is not filtered.

1. Open your Web browser and access the FBR-100AN/FBR-100's Web page.



Note

- For details on how to access the FBR-100AN/FBR-100's Web page using the Web browser, refer to **3-2-2. Displaying FBR-100AN/FBR-100's Web Page.**

2. Click **MAC Address Filter** from the configuration menu.



3. The **MAC Address Filter Configuration** page is displayed.

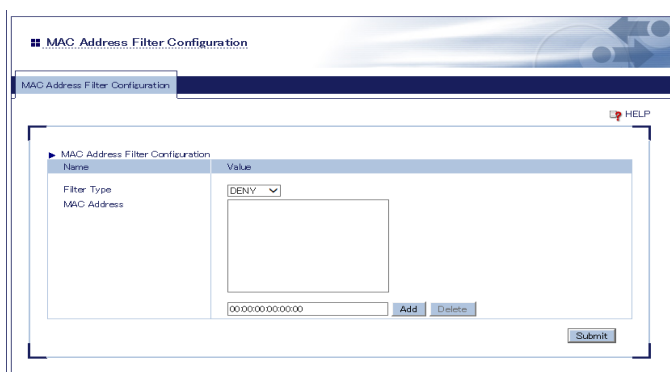

Note

- For details on each configuration item, refer to **A-1. List of All Settings.**

4. Check the settings and click **Submit**.



- The entered settings will be cleared if other configuration items are clicked on the menu. To save the entered settings, click **Submit**.

Note

- The new setting will take effect when FBR-100AN/FBR-100 is turned on next time.

5. The confirmation message for restart is displayed.

To continue the configuration, click the setting item you want to configure from the menu. Click **Restart** to take effect of the new setting when the necessary configuration is finished.

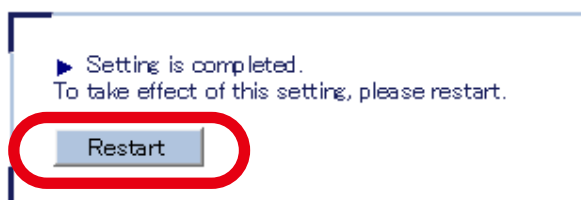

TIP

- Do not turn off FBR-100AN/FBR-100 when the restart is in progress.



Note

- FBR-100AN/FBR-100 can also be restarted by clicking **Restart** from the configuration menu.

6. When the restart is finished and the login page of FBR-100AN/FBR-100 is displayed again, the configuration is completed.



Note

- If the IP address or network operation mode is changed on FBR-100AN/FBR-100 and which does not allow communication from the PC, the login page is not displayed.

4-11. Log Output

The following explains how to output the system log from the Web page.

1. Open your Web browser and access the FBR-100AN/FBR-100's Web page.



Note

- For details on how to access the FBR-100AN/FBR-100's Web page using the Web browser, refer to **3-2-2. Displaying FBR-100AN/FBR-100's Web Page.**

2. Click **Log Output** from the configuration menu.

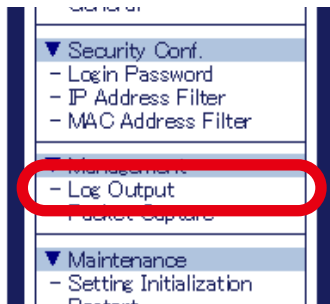

3. The **Log Output** page is displayed.
Click **Save**.

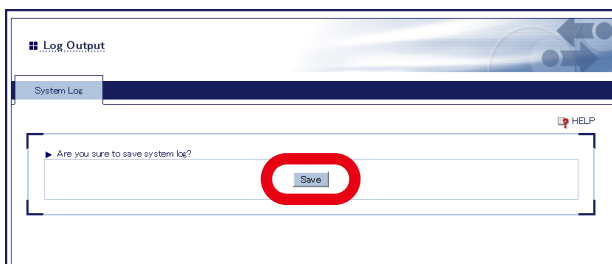

4. Follow the instruction on the dialog to save the log.

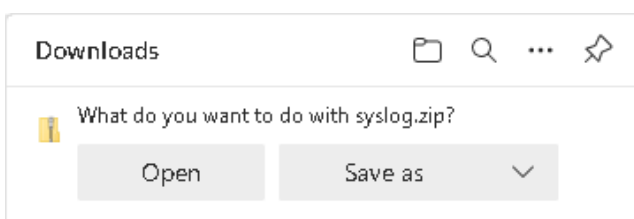

4-12. Packet Capture

The following explains how to capture the network packets using the Web page.

1. Open your Web browser and access the FBR-100AN/FBR-100's Web page.



- For details on how to access the FBR-100AN/FBR-100's Web page using the Web browser, refer to **3-2-2. Displaying FBR-100AN/FBR-100's Web Page.**

Note

2. Click **Packet Capture** from the configuration menu.

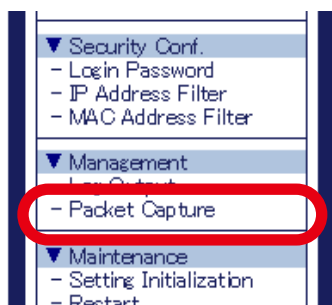

3. The **Packet Capture** page is displayed.
Click **Capture Start** or **Capture Stop**.

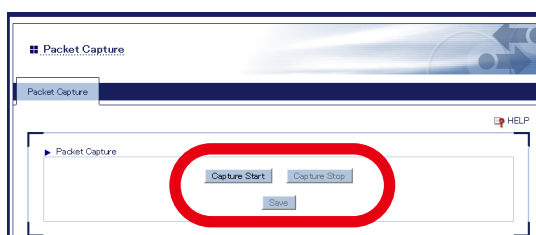

Clicking **Capture Start** will start the packet capture.
Clicking **Capture Stop** will stop the packet capture.

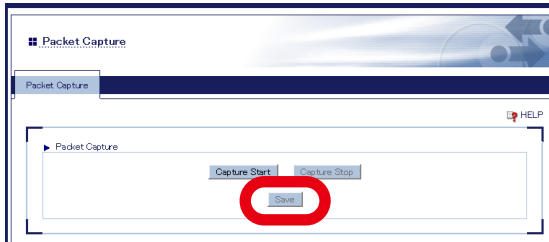
4. Click **Save** to save the captured packets (packet_archive.zip).

The captured data is saved with a file name according to the following rules.
<Interface Name>-<Date>_<Time>.cap<Rotate Count>

Example) Interface Name : eth0, Date : 2019/01/01, Time : 12:30:00, Rotate Count : 0

eth0-20190101_123000.cap0

**Note**

- If the file size exceeds 10MB, it is rotated to another file.
- The maximum number of rotations is 10. When the network operation mode is Edge, and the wireless interface is enabled on 3 interfaces (eth0, eth1, ath0), the maximum 300MB data (10MB x 30) can be saved.
- If a free space of eMMC is 600MB or less, the packet capture does not function since it is also used to save the compressed files.

(blank page)

5. Maintenance Feature

This chapter explains the maintenance feature of FBR-100AN/FBR-100.

- Factory Default Configuration
- Restart
- Firmware Update

5-1. Factory Default Configuration

The following explains how to reset FBR-100AN/FBR-100 to the factory default setting.



TIP

- Once the factory default configuration is executed, all settings of FBR-100AN/FBR-100 are reset to the default ones. It is highly recommended to take a note of the current setting. Remember that not only the product settings but also files and programs of emmc will be initialized.
- Before starting the factory default configuration, make sure that no PCs are accessing FBR-100AN/FBR-100.
- Do not turn off FBR-100AN/FBR-100 when the initialization is in progress.
- Even if the initialization is done, the activation key will remain. To clear the activation key, refer to **A-3-2. Clearing Activation Key**.

5-1-1. Factory Default Configuration Using Web Page

The following explains how to execute the factory default configuration using the Web page.

1. Open your Web browser and access the FBR-100AN/FBR-100's Web page.



Note

- For details on how to access the FBR-100AN/FBR-100's Web page using the Web browser, refer to **3-2-2. Displaying FBR-100AN/FBR-100's Web Page**.

2. Click **Setting Initialization** from the configuration menu.

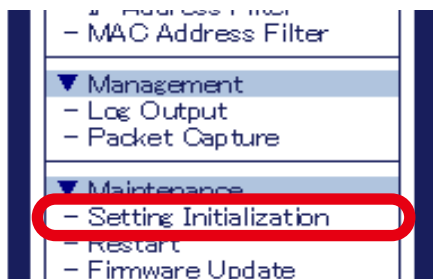

3. The **Setting Initialization** page is displayed.
Select **All** or **Setting Excluding LAN Setting** for **Select the target device to initialize** and click **Execute**.

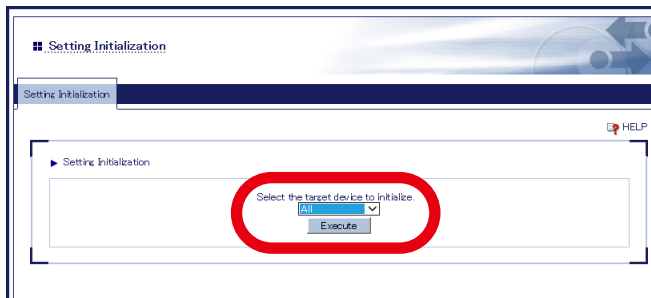

Initialization target	Function
All	Initializes all settings.
Setting Excluding LAN Setting	Initializes the settings other than the general network setting and wireless LAN (STA) setting. * For FBR-100, the settings other than the general network setting will be initialized.

4. Click **OK** to the confirmation message.

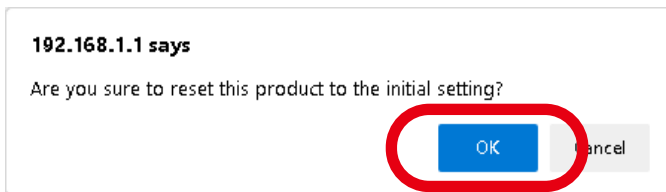

5. The factory default configuration starts.
When it is finished, FBR-100AN/FBR-100 will automatically be restarted.



- Do not turn off FBR-100AN/FBR-100 when the initialization or restart is in progress.

6. When the restart is finished and the login password configuration page of FBR-100AN/FBR-100 is displayed again, the initialization is completed.



- As the IP address of FBR-100AN/FBR-100 is reset to the default one (192.168.1.1), the login page may not be displayed. To access the login page again, the network setting of the PC needs to be changed.

5-1-2. Factory Default Configuration Using Push Switch

The following explains how to execute the factory default configuration using the push switch.

- 1.** Turn off FBR-100AN/FBR-100 by unplugging the DC cable or AC adapter.
- 2.** Press and hold the push switch on the front side of FBR-100AN/FBR-100 while plugging the DC cable or AC adapter back into FBR-100AN/FBR-100 Keep pressing.
- 3.** When all LEDs on top side of FBR-100AN/FBR-100 turn orange, and then all LEDs except for PWR LED turn off, release the push switch.
- 4.** When the PWR LED turns green, the factory default configuration is completed.

5-2. Restart

The following explains how to restart FBR-100AN/FBR-100.

5-2-1. Restart by Unplugging Cables

- 1.** Turn off FBR-100AN/FBR-100 by unplugging the DC cable or AC adapter.
- 2.** Plug the DC cable or AC adapter back into FBR-100AN/FBR-100. Check that the PWR LED turns green on top of FBR-100AN/FBR-100.
- 3.** When all LEDs except for the PWR LED turn on, restart is completed.
(The LED light pattern will differ depending on the configuration or link status of FBR-100AN/FBR-100.)

5-2-2. Restart Using Web Page

The following explains how to restart FBR-100AN/FBR-100 using the Web page.

How to Restart FBR-100AN/FBR-100 Using Web Page

1. Open your Web browser and access the FBR-100AN/FBR-100's Web page.



Note

- For details on how to access the FBR-100AN/FBR-100's Web page using the Web browser, refer to **3-2-2. Displaying FBR-100AN/FBR-100's Web Page.**

2. Click **Restart** from the configuration menu.

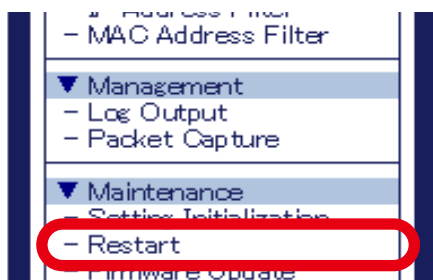

3. The **Restart** page is displayed.
Click **Yes**.

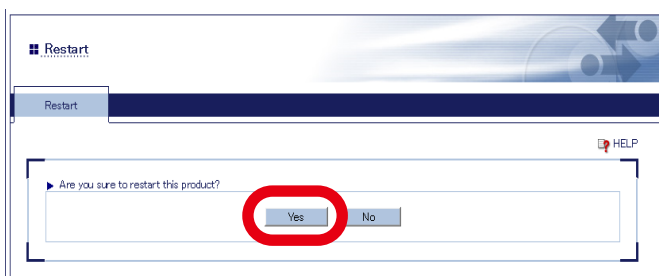

TIP

- Do not turn off FBR-100AN/FBR-100 when the restart is in progress.

4. When the restart is finished, the login page of FBR-100AN/FBR-100 is displayed.

Enter the password, and click [Login].

Password

Select Language
English

**Note**

- If the IP address or network operation mode is changed on FBR-100AN/FBR-100 and which does not allow communication from the PC, the login page is not displayed.

5-3. Firmware Update

The firmware of FBR-100AN/FBR-100 can be upgraded via network.



- When the FBR-100AN/FBR-100 firmware version is Ver.1.4.4 or later, it cannot be downgraded to Ver.1.4.3 or earlier.

5-3-1. Downloading Latest Firmware

Download the latest firmware file from the Silex Technology's website.



Note

- The current firmware version can be found at the bottom left of the Web page.



1. Access the website below on PC.

<https://www.silextechnology.com/>

2. Go to the support page, download the firmware file and extract it on the desktop.

5-3-2. How to Update Firmware

The following explains how to update the FBR-100AN/FBR-100's firmware using the Web page.

1. Open your Web browser and access the FBR-100AN/FBR-100's Web page.



Note

- For details on how to access the FBR-100AN/FBR-100's Web page using the Web browser, refer to **3-2-2. Displaying FBR-100AN/FBR-100's Web Page.**

2. Click **Firmware Update** from the configuration menu.

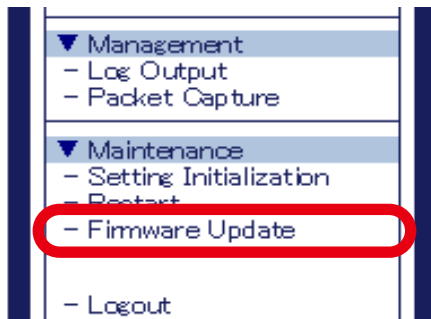

3. The **Firmware Update** page is displayed. Click the **Choose File** button.

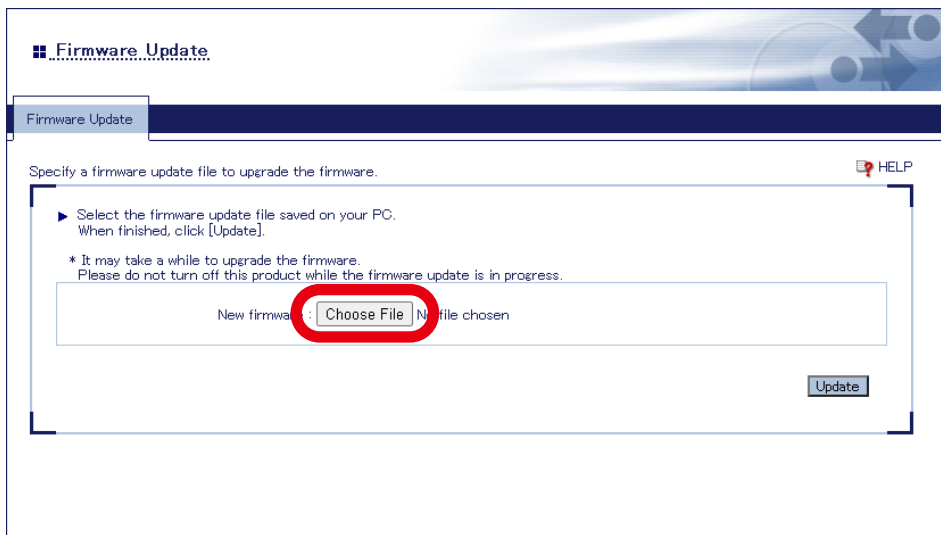

4. In the file selection window, select the firmware update file (FBR-100AN.bin or FBR-100.bin) that you have downloaded from the website and click **Open**.

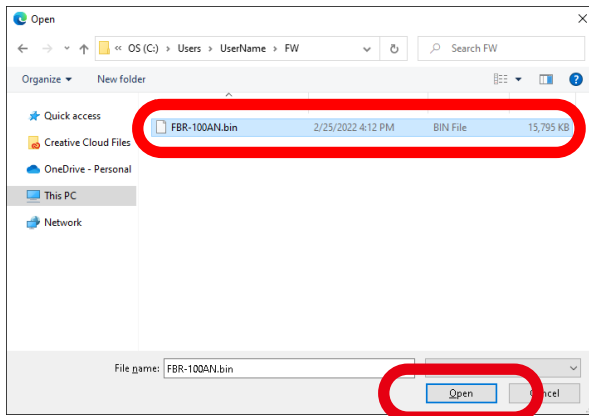

5. Check that the file name is displayed at **New firmware** field and click **Update**.



6. Click **OK** to the confirmation message.

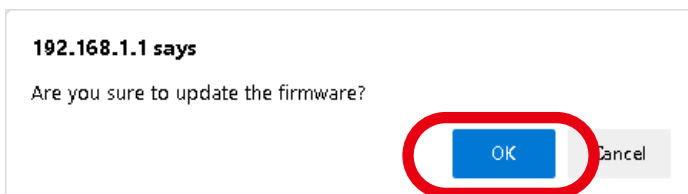

7. The firmware update starts.
When the update is finished, FBR-100AN/FBR-100 will automatically be restarted.

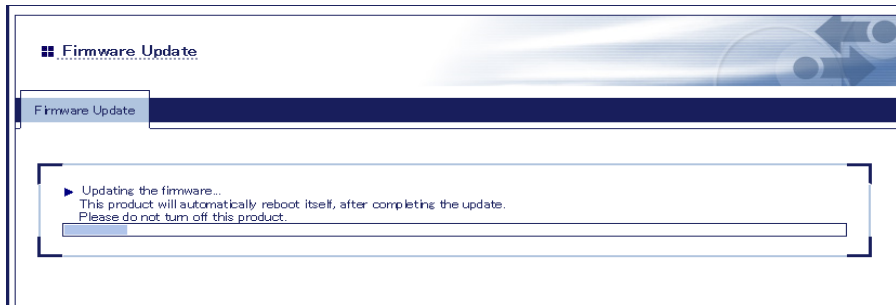

- Do not turn off FBR-100AN/FBR-100 or close your Web browser while the firmware update is in process.
- Do not turn off FBR-100AN/FBR-100 when the restart is in progress.

8. When the restart is finished and the login page is displayed, firmware update is completed. Check that the new firmware version is displayed at the bottom left of Web page.

(blank page)

A. Appendix

This chapter explains each configuration item available on FBR-100AN/FBR-100.

A-1. List of All Settings

The FBR-100AN/FBR-100 has the following configuration items:

A-1-1. Network Configuration

General - General Configuration

Device Configuration

Name	Host Name
Details	Set the host name. Be sure to use a unique name that is not used by other devices.
Range	1-16 character string
Default Value	"FBR-xxxxxx" (xxxxxx is a last 6-digit of the MAC Address)
Name	Wireless Interface (only for FBR-100AN)
Details	Select whether to use the wireless interface.
Range	DISABLE ENABLE
Default Value	DISABLE
Name	Network operation mode
Details	Set the operating mode of FBR-100AN/FBR-100. - Edge IP address/subnet mask are assigned for each interface. - Bridge The specified interfaces are integrated into one, and IP address/subnet mask are assigned to it. For the unspecified interfaces, different IP address/subnet mask are assigned.
Range	Edge Bridge
Default Value	Edge

Name	Default Gateway
Details	Set the default gateway address. If "0.0.0.0" is set, this setting is disabled. When the configured address is not found on the network segment of each interface, the value obtained from DHCP is applied.
Range	0.0.0.0 - 255.255.255.255
Default Value	0.0.0.0
<hr/>	
Name	Link Speed Port 1 / 2
Details	Set a link speed for wired LAN port.
Range	AUTO 10 BASE-T-Half 10 BASE-T-Full 100 BASE-TX-Half 100 BASE-TX-Full 1000 BASE-T-Full
Default Value	AUTO

Name Resolution Protocol Configuration

Name	DNS Suffix
Details	Set the DNS suffix.
Range	0-255 character string (letters, numbers, period, hyphen)
Default Value	(None)
Name	DNS Server (Primary)
Details	Set a primary DNS server address. When DHCP client is enabled, the DNS server address obtained from DHCP server will be applied.
Range	0.0.0.0 - 255.255.255.255
Default Value	0.0.0.0
Name	DNS Server (Secondary)
Details	Set a secondary DNS server address. When DHCP client is enabled, the DNS server address obtained from DHCP server will be applied.
Range	0.0.0.0 - 255.255.255.255
Default Value	0.0.0.0

LAN Port1 / LAN Port2 / WLAN Port / Bridge Port

Name	Add to Bridge (only for FBR-100AN)
Details	When the network operation mode is Bridge , the bridge port setting is displayed. Set the interface to add to the bridge. All : LAN1, LAN2, WLAN are automatically selected. Wired Only : LAN1, LAN2 are automatically selected. Custom : LAN1, LAN2, WLAN can manually be selected.
Range	All / Wired Only / Custom
Default Value	Wired Only
Name	DHCP Client
Details	Select whether to use the DHCP client function.
Range	DISABLE ENABLE
Default Value	DISABLE (LAN Port1, LAN Port2, Bridge Port) ENABLE (WLAN Port)
Name	IP Address
Details	Set an IP address.
Range	0.0.0.0 - 255.255.255.255
Default Value	192.168.1.1 (LAN Port1) 192.168.2.1 (LAN Port2) 0.0.0.0 (WLAN Port) 192.168.3.1 (Bridge Port)
Name	Subnet Mask
Details	Set a subnet mask.
Range	0.0.0.0 - 255.255.255.255
Default Value	255.255.255.0 (LAN Port1, LAN Port2, Bridge Port) 0.0.0.0 (WLAN Port)

General - Bridge Detailed Configuration (Only for FBR-100AN)

Address Management Table Configuration

Configure this setting when it is not possible to communicate with the device that is connected to a wired LAN port of FBR-100AN.

Name	MAC Address
Details	Enter the MAC Address of the device to be connected to a wired LAN port.
Range	00:00:00:00:00:01 - FE:FF:FF:FF:FF:FF
Default Value	00:00:00:00:00:00
Name	DHCP Client
Details	Select whether to enable/disable the DHCP client for the device to be connected to a wired LAN port.
Range	DISABLE ENABLE
Default Value	DISABLE
Name	IP Address
Details	Configure the IP address of the device to be connected to a wired LAN port. This setting can be configured when the DHCP client is set to DISABLE . When it is set to ENABLE , the IP address will be "0.0.0.0".
Range	0.0.0.0 - 255.255.255.255
Default Value	0.0.0.0
Name	Management Table (for IPv4)
Details	This shows the registered MAC address, IP address (IPv4) and DHCP client information of the device to be connected to a wired LAN port (up to 16 addresses). Add : Adds the MAC address, IP address (IPv4) and DHCP client information to the table. Delete : Removes the selected information from the table.
Range	-
Default Value	-

Wireless LAN (STA) - Easy Configuration (Only for FBR-100AN)

Name	SSID
Details	Access Points are searched and shown on the SSID list. Select the SSID of the Access Point you want to connect.
Range	-
Default Value	-
Name	Network Key
Details	Enter the network key to connect the wireless devices. The authentication method will differ depending on the selected Access Point.
Range	When Shared is used: - 5-digit or 13-digit character string - 10-digit or 26-digit hexadecimal number When WPA or WPA2 is used: - A string with 8-64 ASCII characters including symbols
Default Value	(None)

Wireless LAN (STA) - Detailed Configuration (Only for FBR-100AN)

Wireless LAN Basic Configuration

Name	SSID
Details	Set an SSID for wireless LAN of FBR-100AN. SSID is an ID to distinguish one network group from the others in wireless LAN. The devices must share the same SSID to communicate with each other in wireless LAN.
Range	A string with 1-32 ASCII characters including symbols
Default Value	"SSID"
Name	Network Authentication
Details	Select the network authentication mode.
Range	Open Shared WPA2-PSK WPA/WPA2-PSK WPA2-EAP WPA/WPA2-EAP
Default Value	Open
Name	Encryption Mode
Details	Select the encryption mode.
Range	AUTO / AES
Default Value	When WPA2-PSK or WPA2-EAP is used : AES When WPA/WPA2-PSK or WPA/WPA2-EAP is used : AUTO

WEP Configuration

Name	WEP
Details	Enable/Disable the WEP encryption when the network authentication method is set to Open or Shared . If the WEP encryption is used, wireless communication will be encrypted using the settings of WEP Key 1-4 and Key Index .
Range	OFF / ON
Default Value	OFF
Name	Key Index
Details	Select the number of the WEP key to use for encryption (1-4). This setting must be the same as that of your wireless device.
Range	1 / 2 / 3 / 4
Default Value	1
Name	WEP Key1 - 4
Details	Set the WEP key for WEP encryption. Up to 4 WEP keys can be set. This setting must be the same as that of your wireless devices. A WEP key must be entered using hexadecimal or alphanumeric characters.
Range	5 or 13 characters 10 or 26 digit hexadecimal value
Default Value	(None)

WPA/WPA2 PSK Configuration

Name	Pre-Shared Key
Details	Set the Pre-Shared Key for the TKIP/AES encryption. The Pre-Shared Key is a keyword used to create the encryption key. It is also referred to as 'network key' or 'password'.
Range	A string with 8-64 ASCII characters including symbols
Default Value	"PreSharedKey"

WPA/WPA2 EAP Configuration

Name	Authentication Method
Details	Set the authentication method to use for IEEE 802.1X authentication.
Range	EAP-TLS EAP-TTLS PEAP EAP-FAST LEAP
Default Value	EAP-TLS
Name	EAP User Name
Details	Set an EAP user name for the IEEE 802.1X authentication. This name is used by the server to identify a client.
Range	A string with 0-64 ASCII characters including symbols
Default Value	(None)
Name	EAP Password
Details	Set an EAP password for the IEEE 802.1X authentication. It is used to check the reliability of the client when the authentication method other than EAP-TLS is set.
Range	A string with 0-32 ASCII characters including symbols
Default Value	(None)
Name	Inner Authentication Method
Details	Set a method for inner authentication (PAP/CHAP/MSCHAP/MSCHAPv2) to run within TLS tunneling of the IEEE 802.1X authentication. This setting is displayed when the authentication method is set to EAP-TTLS or PEAP, and is fixed to MSCHAPv2 when PEAP is used.
Range	PAP CHAP MSCHAP MSCHAPv2
Default Value	PAP
Name	Client Certificate Password
Details	Set a client certificate password to use for client authentication of IEEE 802.1X authentication. This setting is necessary when a password is set to the client certificate. This is used when EAP-TLS is used as authentication method.
Range	A string with 0-32 ASCII characters including symbols
Default Value	(None)

Name	Client Certification
Details	Select a client certificate to use for client authentication of IEEE 802.1X authentication. This is used when EAP-TLS is used as authentication method.
Range	Upload the client certificate.
Default Value	-
Name	Server Authentication
Details	Set whether to verify that the server certificate is issued from a trusted root certification authority when EAP-TLS, EAP-TTLS or PEAP authentication mode is used. When this setting is enabled, CA certificate is required since verification of the server certificate runs.
Range	OFF / ON
Default Value	OFF
Name	CA Certification
Details	Select a CA certificate to use for server authentication. This setting is displayed when the server authentication is enabled.
Range	Upload the CA certificate.
Default Value	-
Name	Auto PAC Provisioning
Details	Enable/Disable automatic distribution of PAC file. When this setting is disabled, the PAC file issued from the server is required. This setting is displayed when the authentication method is set to EAP-FAST.
Range	OFF / ON
Default Value	OFF
Name	PAC File Distribution
Details	Register the PAC file issued from the server to use for manual distribution of PAC (Protected Access Credential) when using EAP-FAST authentication. This setting is displayed when the authentication method is set to EAP-FAST.
Range	Upload the PAC file.
Default Value	-

Certificate Registration Status

When **WPA2-EAP** or **WPA/WPA2-EAP** is selected for network authentication, the registration status of following certificates is displayed.

Name	Client Certification
Details	This is a certificate file to authenticate FBR-100AN for IEEE802.1X authentication.
Range	The certificate registration status is displayed. Not Registered Registered
Default Value	Not Registered
Name	CA Certification
Details	This is a CA certificate file to authenticate a certificate sent from the RADIUS server when IEEE802.1X authentication is used.
Range	The certificate registration status is displayed. Not Registered Registered
Default Value	Not Registered
Name	PAC File Distribution
Details	Register the PAC file issued from the server to use for manual distribution of PAC (Protected Access Credential) when using EAP-FAST authentication.
Range	The certificate registration status is displayed. Not Registered Registered
Default Value	Not Registered

IEEE802.1X Network Device Configuration

Name	Device Filter
Details	Enable/Disable a filter for the devices registered to the address management table. When this setting is disabled, data is bridged to wireless network even if the connected devices are not registered to the address management table of the bridge detailed setting. The security feature of IEEE802.1X device authentication will not be available then.
Range	OFF (Disable) / ON (Enable)
Default Value	ON

MTConnect Configuration - Common Configuration

Common Configuration

Name	MTConnect Mode
Details	<p>Set the MTConnect operating mode.</p> <ul style="list-style-type: none"> - agent & adapter When accessed from the client, FBR-100AN/FBR-100 replies in XML format data. - adapter When accessed from the client, FBR-100AN/FBR-100 replies in SHDR format data (format with vertical separation lines ' '). - agent When accessed from the client, FBR-100AN/FBR-100 replies in XML format data. From the adapter, SHDR format data (format with vertical separation lines ' ') is collected.
Range	agent & adapter adapter agent
Default Value	agent & adapter
Name	Data Acquisition Mode
Details	<p>Set the MTConnect data collection mode.</p> <ul style="list-style-type: none"> - Network The data of each point is collected individually according to the point setting. - DPRNT The DPRNT specification data is collected at once after it is sent from serial (RS-232C). - agent Agent mode is on. The data is collected from the adapter. - AirGRID® Only information of the stack tower light can be collected using the wireless communication system AirGRID® developed by PATLITE Corporation. Up to 30 AirGRID® transmitters can be used.
Range	Network DPRNT agent AirGRID®
Default Value	Network

MTConnect Configuration - Network Configuration

Network Configuration1 - 3

Up to 3 CNC devices can be specified for **Network Configuration**.

When multiple CNC devices are connected, the number of collectable data is limited.

Name	MTConnect Port(HTTP)
Details	Set the port number to be used for MTConnect (HTTP) communication.
Range	0 - 32767
Default Value	5000 - 5002 (when MTConnect Mode is agent & adapter) 7878 - 7880 (when MTConnect Mode is adapter)
Name	MTConnect Port(HTTPS)
Details	Set the port number to be used for MTConnect (HTTPS) communication.
Range	0 - 32767
Default Value	5443 - 5445 (when MTConnect mode is agent & adapter) 7443 - 7445 (when MTConnect mode is adapter)
Name	CNC ID
Details	Set the ID to identify CNC. For the Device Name to be registered on MTConnect client software, use this name. (This is set to 'Device name' on XML.)
Range	1-32 characters, numbers and hyphens (-) can be used. For the beginning of the value, only characters can be used.
Default Value	FBR-xxxxxx-01 to 03 (xxxxxx is a lower 6 byte of the MAC Address)
Name	CNC IP Address
Details	Set the IP address of CNC to be connected.
Range	0.0.0.0 - 255.255.255.255
Default Value	0.0.0.0
Name	CNC Port
Details	Set the port number of CNC to be connected.
Range	0 - 65535
Default Value	8193

Name	Point file
Details	Import the point file that has been used for the older version of FBR-100AN/ FBR-100 (1.4.1 or lower). Browse : Specifies the point file to import. Import : Imports the specified point file.
Range	-
Default Value	-

AirGRID® Migration Configuration

Name	AirGRID® Migration
Details	Enable/disable the AirGRID® integrated collection function. The information of CNC and stack tower light can be collected and merged using AirGRID® of PATLITE Corporation.
Range	ENABLE / DISABLE
Default Value	DISABLE
Name	WDR IP Address
Details	Set the IP address of the AirGRID® WDR receiver.
Range	0.0.0.0 - 255.255.255.255
Default Value	0.0.0.0
Name	WDT MAC Address (for Network Configuration 1-3)
Details	Set the MAC address of the AirGRID® WDT transmitter to monitor. (The same value cannot be used twice.)
Range	16 alphanumeric characters
Default Value	0000000000000000

MTConnect Configuration - Network Configuration - Default Point Configuration

The default point configuration page can be displayed by clicking **Default Point Configuration** at the network configuration page.

Default Point Configuration (Network Configuration1 - 3)

The following settings can be configured for the default point.

Details	Set whether to collect each point (ON/OFF) and the collection interval.
Range	Whether to collect : ON (to collect) / OFF (not to collect) Collection interval [ms] : 100 - 10000

Custom Macro Collective Configuration (Network Configuration1)

Custom Macro Collective Configuration is on **Network Configuration1** only.

Name	CNC Path Number
Details	Set the CNC path number.
Range	1 - 10
Default Value	1
Name	Start Number
Details	Set the number of data to start the data collection from. Starting from the specified number, quantity of data as specified at Quantity will be collected.
Range	1 - 33, 100 - 199, 500 - 999
Default Value	(None)
Name	Quantity
Details	Specify the quantity of data to collect.
Range	1 - 500
Default Value	1
Name	Collection Interval[ms]
Details	Set the interval for data collection.
Range	100 - 10000
Default Value	1000

PMC Collective Configuration (Network Configuration1)

PMC Collective Configuration is on **Network Configuration1** only.

Name	PMC Path Number
Details	Set the PMC path number.
Range	1 - 5
Default Value	1
Name	Address Type
Details	Set the PMC address type.
Range	A/C/D/E/F/G/K/M/N/R/T/X/Y/Z
Default Value	A
Name	Starting Address
Details	Set the start address to start the data collection from. Starting from the specified address, volume of data as specified at Size[Byte] will be collected.
Range	0 - 59999
Default Value	(None)
Name	Size[Byte]
Details	Set the size of data to collect at a time. The size must be divisible by 4.
Range	1 - 3000
Default Value	1
Name	Collection Interval[ms]
Details	Set the interval for data collection.
Range	100 - 10000
Default Value	1000

Tool Offset Collective Configuration (Network Configuration1)

Tool Offset Collective Configuration is on **Network Configuration1** only.

Name	CNC Path Number
Details	Set the CNC path number.
Range	1 - 10
Default Value	1
Name	Start Number
Details	Set the number of data to start the data collection from. Starting from the specified number, quantity of data as specified at Quantity will be collected.
Range	1 - 200
Default Value	(None)
Name	Quantity
Details	Specify the quantity of data to collect.
Range	1 - 200
Default Value	1
Name	Collection Interval[ms]
Details	Set the interval for data collection.
Range	100 - 10000
Default Value	1000

MTConnect Configuration - Network Configuration - Custom Point Configuration

The custom point configuration page can be displayed by clicking **Custom Point Configuration** at the network configuration page.

Users can create the point to collect that data from the CNC.

Up to 130 custom points can be added.

Custom Point Configuration (Network Configuration1 - 3)

Name	CNC path
Details	Set the CNC path number.
Range	1 - 10
Default Value	1
Name	PMC path
Details	Set the PMC path number.
Range	1 - 5
Default Value	1
Name	DCS Ladder
Details	Enable/Disable the DCS Ladder. When a dual check safety function can be used, enable it.
Range	DISABLE / ENABLE
Default Value	DISABLE

Custom Point List

The custom point addition screen can be displayed by clicking **Add New Point**. Configure the following settings.

Name	Point Name
Details	Set the name of the point to collect.
Range	50 or less alphanumeric characters (the first input must be an alphabetic character)
Default Value	(None)
Name	Point Type
Details	Set the category of data to collect.
Range	EVENT/SAMPLE/CONDITION
Default Value	(None)
Name	Constant Value
Details	<p>This setting differs depending on what is chosen at Point Type.</p> <p>When EVENT is selected: By registering the device name or identification number to this setting, the devices can be identified.</p> <p>When CONDITION is selected: PMC alarm numbers or PMC message numbers can be entered by separating them with spaces (up to 10 numbers can be entered).</p>
Range	<p>When EVENT is selected: 10 or less alphanumeric characters</p> <p>When CONDITION is selected: PMC alarm: 1000 - 1999 PMC message number: 2000 - 2999</p>
Default Value	(None)
Name	Update Cycle
Details	Set the cycle for data update.
Range	100 - 10000 [ms]
Default Value	(None)

Name	Unit
Details	Set the unit of the data that can be acquired when SAMPLE is selected for Point Type .
Range	NONE AMPERE CELSIUS COUNT DECIBEL DEGREE DEGREE/SECOND DEGREE/SECOND^2 HERTZ JOULE KILOGRAM LITER LITER/SECOND MICRO_RADIAN MILLIMETER MILLIMETER/SECOND MILLIMETER/SECOND^2 MILLIMETER_3D NEWTON NEWTON_METER OHM PASCAL PASCAL_SECOND PERCENT PH REVOLUTION/MINUTE SECOND SIEMENS/METER VOLT VOLT_AMPERE VOLT_AMPERE_REACTIVE WATT WATT_SECOND
Default Value	NONE

Name	XML Location
Details	<p>When MT Connect Mode is agent & adapter, the response data is output in XML. Set the contents to output in XML.</p> <p>* The following red portions can be output in XML.</p> <pre> graph TD Devices[Devices] --- Device[Device] Device --- Components1[Components] Components1 --- Controller[Controller] Components1 --- Axes[Axes] Controller --- Components2[Components] Components2 --- Path[Path] Path --- LinearX[Linear - X Axis] Path --- LinearY[Linear - Y Axis] Path --- LinearZ[Linear - Z Axis] Axes --- Components3[Components] Components3 --- RotaryC[Rotary - C Axis] </pre>
Range	<p>Device / Controller / Path / Path2 - Path10</p> <p>- Path2 - Path10 can be selected when CNC path is 2 or larger. Path2 - Path5 can be selected when CNC path is 5.</p>
Default Value	Device
Name	Data Point Path/Channel
Details	Set the data point path to use.
Range	<p>CNC path X PMC path Y DCS path 9</p> <p>- X is the value set at CNC path and Y is the value set at PMC path. - CNC path 1 - CNC path X, PMC path 1 - PMC path Y can be selected when CNC path or PMC path is 2 or larger. - DCS path 9 can be set when DCS Ladder is ENABLE.</p>
Default Value	(None)

Name	Data Type
Details	Set the data type according to the settings configured at Data Point Path / Channel .
Range	<p>When Data Point Path/Channel is CNC path :</p> <p>Common Macro Variables (#100-#199) Common Macro Variables (#500-#999) Local Macro Variables (#1-#33)</p> <p>When Data Point Path/Channel is PMC path and Point Type is EVENT:</p> <p>PMC 2Byte PMC 4Byte PMC Bit PMC Byte PMC String</p> <p>Others: PMC 2Byte PMC 4Byte PMC Bit PMC Byte</p>
Default Value	(None)
Name	Address Type
Details	Set the address type. This setting can be configured when Data Point Path/Channel is PMC path Y or DCS path 9 .
Range	A/C/D/E/F/G/K/M/N/R/T/X/Y/Z
Default Value	A
Name	Starting Address
Details	Set the start address according to the setting configured at Data Type .
Range	<p>When Data Type is Common Macro Variables (#100-#199): Integer value from 100 - 199</p> <p>When Data Type is Common Macro Variables (#500-#999): Integer value from 500 - 999</p> <p>When Data Type is Common Macro Variables (#1-#33): Integer value from 1 to 33</p> <p>When Data Type is other than above: Integer value from 0 to 59999</p>
Default Value	(None)

Name	Bit Position
Details	Set the bit position. This setting can be configured when Data Type is PMC Bit .
Range	0 - 7
Default Value	(None)
Name	String Size
Details	Set the string size. This setting can be configured when Data Type is PMC String .
Range	1 - 500
Default Value	(None)



Note

- In order to obtain '100 of custom macro', specify the settings as follows at **Custom Point Configuration**.

Click "Add" after inputting each item.
To cancel the input, press ESC key or the "X" to the right.
After you have finished adding all the custom points, press "Submit" on the original page.

Name	Value
Point Name	sample1
Point Type	EVENT
Constant Value	
Update Cycle	100
XML Location	Device
Data Point Path/Channel	CNC path 1
Data Type	Common Macro Variables(#100-#199)
Starting Address	100

Add

- In order to obtain '1 byte of PMC R100', specify the settings as follows at **Custom Point Configuration**.

Click "Add" after inputting each item.
To cancel the input, press ESC key or the "X" to the right.
After you have finished adding all the custom points, press "Submit" on the original page.

Name	Value
Point Name	sample2
Point Type	SAMPLE
Update Cycle	100
Unit	COUNT
XML Location	Device
Data Point Path/Channel	PMC path 1
Data Type	PMC Byte
Address Type	R
Starting Address	100

Add

MTConnect Configuration - DPRNT Configuration

DPRNT Configuration

Only one CNC device can be specified for **DPRNT Configuration**.

Name	MTConnect Port(HTTP)
Details	Set the port number to be used for MTConnect (HTTP) communication. This setting is used even when DPRNT is selected for the data acquisition mode.
Range	0 - 32767
Default Value	5000 (when MTConnect mode is agent & adapter) 7878 (when MTConnect mode is adapter)
Name	MTConnect Port(HTTPS)
Details	Set the port number to be used for MTConnect (HTTPS) communication. This setting is used even when DPRNT is selected for the data acquisition mode.
Range	0 - 32767
Default Value	5443 (when MTConnect mode is agent & adapter) 7443 (MTConnect mode is adapter)

MTConnect Configuration - agent Mode Configuration

agent Mode Configuration1 - 3

Up to 3 adapter devices can be specified for **agent Mode Configuration**.

When multiple adapter devices are connected, the number of collectable data is limited.

Name	MTConnect Port(HTTP)
Details	Set the port number to be used for MTConnect (HTTP) communication.
Range	0 - 32767
Default Value	5000 - 5002
Name	MTConnect Port(HTTPS)
Details	Set the port number to be used for MTConnect (HTTPS) communication.
Range	0 - 32767
Default Value	5443 - 5445
Name	adapter IP Address
Details	Set the IP address of adapter to be connected.
Range	0.0.0.0 - 255.255.255.255
Default Value	0.0.0.0
Name	adapter Port
Details	Set the port number of adapter to be connected.
Range	0 - 65535
Default Value	7878 - 7880
Name	Devices.xml
Details	Import or delete the device file (Devices.xml). Browse : Specifies the device file to import or delete. Import : Imports the specified device file. Delete : Deletes the imported device file.
Range	-
Default Value	-

MTConnect Configuration - AirGRID® Configuration

AirGRID® Configuration for Single Operation

Up to 30 AirGRID® transmitters can be used. Only information of the stack tower light is collected, and converted to MTConnect and then the upper system is connected.

Name	WDR IP Address
Details	Set the IP address of the AirGRID® WDR receiver.
Range	0.0.0.0-255.255.255.255
Default Value	0.0.0.0
Name	MAC Address
Details	Set the MAC address of the AirGRID® WDT transmitter to monitor. (The same value cannot be used twice.) Clicking [Acquisition] will acquire the MAC address of the WDT being connected to the WDR, and then will reflect it in the input form. This is valid only when all WDT MAC addresses are defaults.
Range	16 alphanumeric characters
Default Value	0000000000000000
Name	MTConnect Port (HTTP)
Details	Set the port number for MTConnect(HTTP) communication.
Range	0-32767
Default Value	5000 - 5029 (when MTConnect mode is agent & adapter) 7878 - 7907 (when MTConnect mode is adapter)
Name	MTConnect Port (HTTPS)
Details	Set the port number for MTConnect(HTTPS) communication.
Range	0-32767
Default Value	5443 - 5472 (when MTConnect mode is agent & adapter) 7443 - 7472 (when MTConnect mode is adapter)

FTP Configuration

FTP Server Configuration

Name	User name
Details	Set the user name to access FTP.
Range	Acceptable characters are 0 to 9, a to z, A to Z, and - (hyphen). The hyphen cannot be used at the beginning and end of the string. Up to 32 characters can be used. It is impossible to use phrases already used in the system. Example) root, nobody, daemon, bin, sys, sync, proxy, sshd, default, ftp
Default Value	admin
Name	Password
Details	Set the password to access FTP.
Range	Acceptable characters are 0 to 9, a to z, A to Z, and - (hyphen). The hyphen cannot be used at the beginning and end of the string. Up to 32 characters can be used.
Default Value	admin
Name	FTP Status
Details	Start/Stop FTP.
Range	start / stop Start FTP : Starts the FTP function Stop FTP : Finish the FTP function
Default Value	stop

Time Configuration

Date

The current time is displayed.

Timezone Configuration

Name	Time Zone
Details	Set the time zone.
Range	Hour : -13 to +14 Minute : 00 / 15 / 30 / 45
Default Value	+9:00

Date and Time Configuration

Name	NTP Function
Details	Enable/Disable the NTP protocol.
Range	ENABLE DISABLE
Default Value	DISABLE
Name	NTP Server
Details	Enter the domain name or IP address of the NTP server.
Range	When domain name is used: 0-128 character string (letters, numbers, period, hyphen) When IP address is used: 0.0.0.0 - 255.255.255.255
Default Value	(None)
Name	Manual Configuration
Details	Set the time setting manually.
Range	Year : 2019-2035 Month : 1-12 Day : 1-31 Hour : 00-23 Minute : 00-59
Default Value	(None)
Note	Configuration using AMC Manager® is not supported.

A-1-2. Serial Configuration

General Configuration

General Configuration

Name	Baud Rate[baud]
Details	Set the data transmission/reception speed for the port.
Range	300 600 1200 1800 2400 4800 9600 19200 28800 38400 57600 115200
Default Value	4800
Name	Bits per Character[bit]
Details	Set the number of bits per character.
Range	7 / 8
Default Value	8
Name	Stop bit[bit]
Details	Set the number of stop bits after each character.
Range	1 / 2
Default Value	2
Name	Parity
Details	Select the parity scheme for each character.
Range	None Odd Even
Default Value	None

Name	Flow Control
Details	Select the flow control method.
Range	None XON/XOFF RTS/CTS
Default Value	None

A-1-3. Security Configuration

Login Password Configuration

Name	New Password
Details	Configure the password for FBR-100AN/FBR-100. This password is used as authentication password when configuration is changed using Web browser.
Range	1-15 alphanumeric character
Default Value	(none)
Name	Confirm New Password
Details	Enter the same password as New Password .
Range	1-15 alphanumeric character
Default Value	(none)

IP Address Filter Configuration

Default Filter Mode

Name	Default Filter Mode
Details	Configure the access control setting (ALLOW / DENY) for all IP addresses. ALLOW : Allows access from all IP addresses. DENY : Denies access from all IP addresses. This setting is used with Filter Mode . When Default Filter Mode is set to DENY , FBR-100AN/FBR-100 accepts access only from the devices whose range of IP address is allowed at Filter Mode . * When Default Filter Mode is set to DENY and no IP addresses are registered at the filter condition, this setting is invalidated and FBR-100AN/FBR-100 accepts any accesses.
Range	DENY ALLOW
Default Value	ALLOW

New Conditions

Name	Filter Mode
Details	Configure the filter mode (ALLOW / DENY) for the specified address range. ALLOW : Allows access from the registered IP address range. DENY : Denies access from the registered IP address range.
Range	DENY ALLOW
Default Value	DENY
Name	Starting Address
Details	Set the start address for address filter. Up to 20 addresses can be registered.
Range	0.0.0.0 - 255.255.255.255
Default Value	0.0.0.0
Name	Ending Address
Details	Set the end address for address filter. Up to 20 addresses can be registered.
Range	0.0.0.0 - 255.255.255.255
Default Value	0.0.0.0

Registered Condition Management

Name	Registered Conditions
Details	Shows the registered address filter conditions.
Range	(Filter Mode) : (Start Address) - (End Address)
Default Value	None (blank)
Name	Priority Configuration
Details	Set the priority of the registered conditions.
Range	↑ : Set Priority Higher / ↓ : Set Priority Lower
Default Value	-

MAC Address Filter Configuration

MAC Address Filter Configuration

Name	Filter Type
Details	Set a security type for MAC Address filter (DENY/ALLOW). DENY : Denies access from the devices registered to MAC Address filter list. ALLOW : Allows access only from the devices registered to MAC Address filter.
Range	ALLOW DENY
Default Value	DENY
Name	MAC Address
Details	Set the MAC Address filter. By registering the MAC Address filter, access to FBR-100AN/FBR-100 can be controlled. (Up to 20 addresses can be registered.) * If the filter type is set to ALLOW and MAC Address (to allow access from) is not registered, access to FBR-100AN/FBR-100 is invalidated.
Range	00:00:00:00:00:01 - FF:FF:FF:FF:FF:FE
Default Value	00:00:00:00:00:00

A-2. List of Error Codes

Error Code	State/Solution
71-16	FBR-100AN/FBR-100 cannot communicate with CNC. Check the IP address and port number of CNC.
02XX	The following information cannot be obtained from CNC. Eliminate from the data collection target and see how it works. Emergency stop status CNC operating mode CNC operating status
03XX	The following information cannot be obtained from CNC. Eliminate from the data collection target and see how it works. Operator message display
04XX 05XX 06XX	The following information cannot be obtained from CNC. Eliminate from the data collection target and see how it works. Alarm message display
08XX	The following information cannot be obtained from CNC. Eliminate from the data collection target and see how it works. Absolute position
09XX	The following information cannot be obtained from CNC. Eliminate from the data collection target and see how it works. Feed speed
11XX	The following information cannot be obtained from CNC. Eliminate from the data collection target and see how it works. Sequence number of the executed program
12XX	The following information cannot be obtained from CNC. Eliminate from the data collection target and see how it works. Main program name Main program comment
13XX	The following information cannot be obtained from CNC. Eliminate from the data collection target and see how it works. Main program name
14XX	The following information cannot be obtained from CNC. Eliminate from the data collection target and see how it works. Main program comment

Error Code	State/Solution
15XX	<p>The following information cannot be obtained from CNC.</p> <p>Eliminate from the data collection target and see how it works. Tool number</p>
16XX	<p>The following information cannot be obtained from CNC.</p> <p>Eliminate from the data collection target and see how it works. Feed speed override Rapid override Spindle override Dry run Cutting feed M00 M01 Custom Point PMC Collective Configuration Serial Spindle Load</p>
17XX	<p>The following information cannot be obtained from CNC.</p> <p>Eliminate from the data collection target and see how it works. Block of the executed program</p>
18XX	<p>The following information cannot be obtained from CNC.</p> <p>Eliminate from the data collection target and see how it works. Moving axis load</p>
19XX	<p>The following information cannot be obtained from CNC.</p> <p>Eliminate from the data collection target and see how it works. Spindle load</p>
20XX	<p>The following information cannot be obtained from CNC.</p> <p>Eliminate from the data collection target and see how it works. Spindle speed</p>
21XX	<p>The following information cannot be obtained from CNC.</p> <p>Eliminate from the data collection target and see how it works. Spindle operating mode</p>
22XX 23XX	<p>The following information cannot be obtained from CNC.</p> <p>Eliminate from the data collection target and see how it works. Effective axis name</p>
24XX 25XX	<p>The following information cannot be obtained from CNC.</p> <p>Eliminate from the data collection target and see how it works. Custom Point</p>
26XX	<p>The following information cannot be obtained from CNC.</p> <p>Eliminate from the data collection target and see how it works. Custom Point PMC Collective Configuration</p>

Error Code	State/Solution
28XX	The following information cannot be obtained from CNC. Eliminate from the data collection target and see how it works. Number of parts feed speed override Cycle time
29XX	The following information cannot be obtained from CNC. Eliminate from the data collection target and see how it works. Moving axis load current value
33XX	The following information cannot be obtained from CNC. Eliminate from the data collection target and see how it works. Spindle insulation resistance value Moving axis insulation resistance value All servo/spindle power consumption value Total axis moving distance
35XX	The following information cannot be obtained from CNC. Eliminate from the data collection target and see how it works. Real speed for servo adjustment
36XX	The following information cannot be obtained from CNC. Eliminate from the data collection target and see how it works. Custom Macro Collective Configuration
37XX	The following information cannot be obtained from CNC. Eliminate from the data collection target and see how it works. Tool Offset Collective Configuration
38XX	The following information cannot be obtained from CNC. Eliminate from the data collection target and see how it works. Spindle speed
39XX 40XX	The following information cannot be obtained from CNC. Eliminate from the data collection target and see how it works. Specification Program Comment
41XX	The following information cannot be obtained from CNC. Eliminate from the data collection target and see how it works. Serial Spindle Load
Others	Capture the log and contact our customer support.

A-3. Activation

By registering the activation key to FBR-100AN/FBR-100, the optional function (non-free) can be enabled.

A-3-1. Registering Activation Key

The following explains how to register the issued activation key.

1. Turn on FBR-100AN/FBR-100 while the DIP Switch 4 is ON.

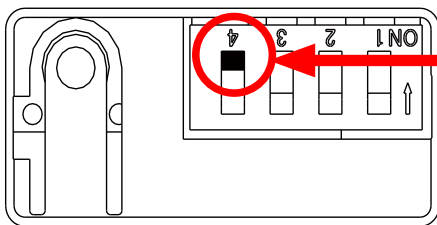

Make sure that the DIP Switch 4 is ON.

2. Open your Web browser and access the FBR-100AN/FBR-100's Web page. When the activation key registration page is displayed, enter the issued activation key and click **Register**.

Welcome to FBR-100AN

Enter the activation key you got and click [Register].
This product will automatically be restarted.

Activation Key

When you do not want to register the activation key, turn off the DIP Switch 4 of this product and then restart it.

Select Language
English



Note

- For details on how to access the FBR-100AN/FBR-100's Web page using the Web browser, refer to **3-2-2. Displaying FBR-100AN/FBR-100's Web Page.**
- When the activation key has already been registered, the activation key registration page does not appear.
- When you do not want to register the activation key, turn off the DIP Switch 4 (same as factory default setting) and click **Restart**.

3. Click **OK** to the confirmation message. The activation key will be registered and FBR-100AN/FBR-100 will automatically be restarted.

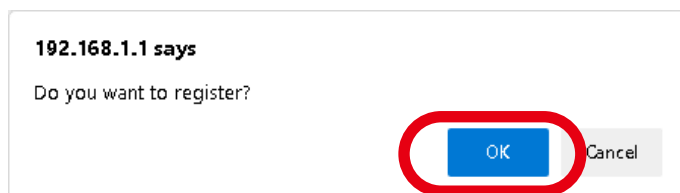
**Note**

- If the activation key is not correct, the registration does not perform correctly.

A-3-2. Clearing Activation Key

1. Click **Activation Initialization** from the configuration menu.

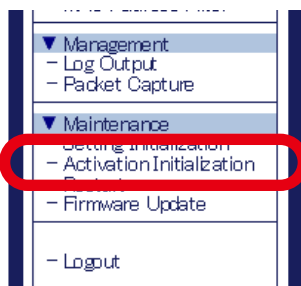

- This menu (**Activation Initialization**) is not displayed when the activation key is not registered.

TIP

2. When the activation initialization page is displayed, click **Execute**.

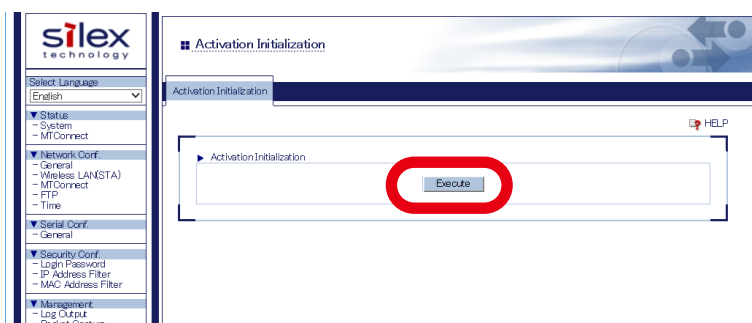

3. Click **OK** to the confirmation message. The registered activation key and setting will be deleted.

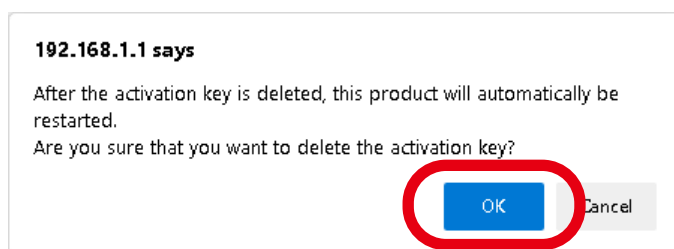

- The setting of the function (that has been enabled by registering the activation key) will remain even if the activation key is cleared. To reset the setting of the enabled function, refer to **5-1. Factory Default Configuration**.

TIP

A-4. Using OPC UA Activation

The following explains the basic procedure to use the OPC UA function of FBR-100AN/FBR-100.

A-4-1. What is OPC UA?

- OPC UA (OPC Unified Architecture) is an open and international data exchange standard that is used in Industry 4.0. This realizes secure interconnect communication across multi-vendor products and different operating systems.
- By applying the OPC UA activation to FBR-100AN/FBR-100, the following can be supported.
 - FBR-100AN/FBR-100 can be used as the OPC UA server.
 - Collection and exchange of the operating data in compliance with the Industry 4.0 platform umati (universal machine technology interface) for machine tools
 - Data exchange and unified operation monitoring for OPC UA-compatible PLCs and HMIs

[FBR-100AN/FBR-100 OPC UA function compatibility]

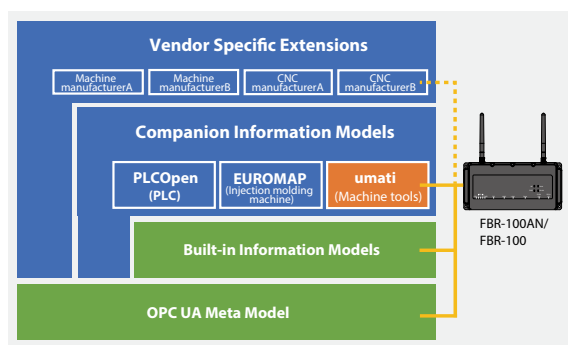

[Use image of OPC UA communication]

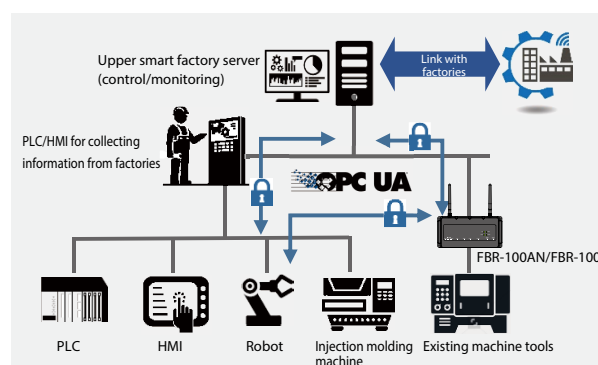

- To use the OPC UA activation, the activation key needs to be registered in advance.
For details, refer to **A-3-1. Registering Activation Key.**

A-4-2. Network Connection to Use OPC UA Activation

Up to 3 CNC devices can be used for the OPC UA function of FBR-100AN/FBR-100. The client software of the upper smart factory system can collect the operating data of each CNC device by individually accessing each OPC UA server that runs inside FBR-100AN/FBR-100.

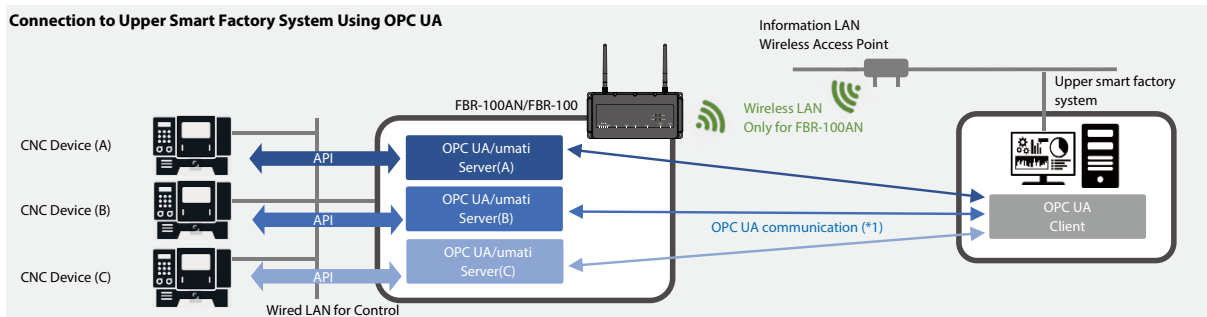

(* 1) When reading information of multiple CNC devices from the OPC UA client, specify the number of communication port assigned to each OPC UA server.



Note

- FBR-100AN/FBR-100 does not contain the OPC UA client-compatible software. Please purchase the one that is commercially available in the market.
- For the CNC devices that can be used by this activation and the detailed configuration method, see the FBR-100AN/FBR-100's catalog or visit our website.

A-4-3. Showing OPC UA Status

OPC UA status shows the OPC UA setting.

1. Open your Web browser and access the FBR-100AN/FBR-100's Web page.



Note

- For details on how to access the FBR-100AN/FBR-100's Web page using the Web browser, refer to **3-2-2. Displaying FBR-100AN/FBR-100's Web Page.**

2. Click **OPC UA** from the configuration menu.

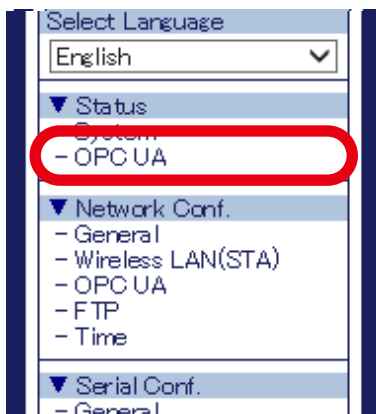

3. The **OPC UA Status** page is displayed.

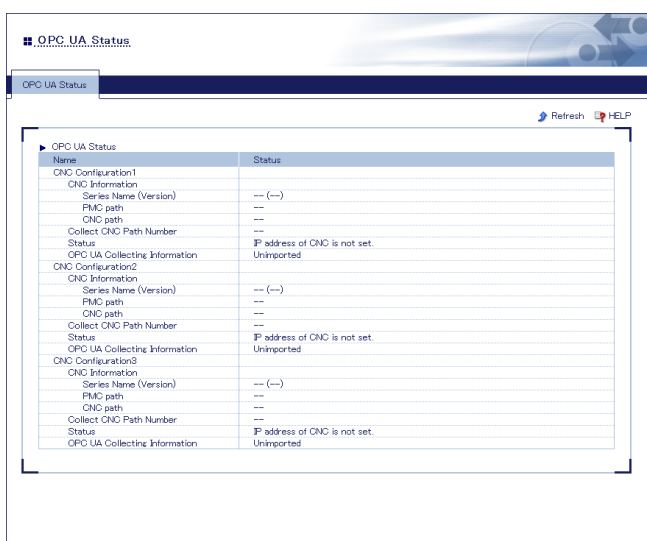

A-4-4. OPC UA Setting

The following explains how to configure the OPC UA setting.

For details, see the reference documents that can be found on the Silex Technology's website.

1. Open your Web browser and access the FBR-100AN/FBR-100's Web page.



Note

- For details on how to access the FBR-100AN/FBR-100's Web page using the Web browser, refer to **3-2-2. Displaying FBR-100AN/FBR-100's Web Page.**

2. Click **OPC UA** from the configuration menu.

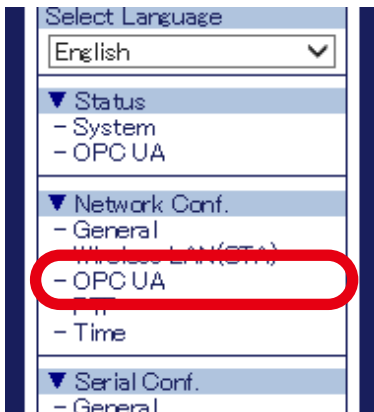

3. The **OPC UA Configuration** page is displayed. Configure each setting.

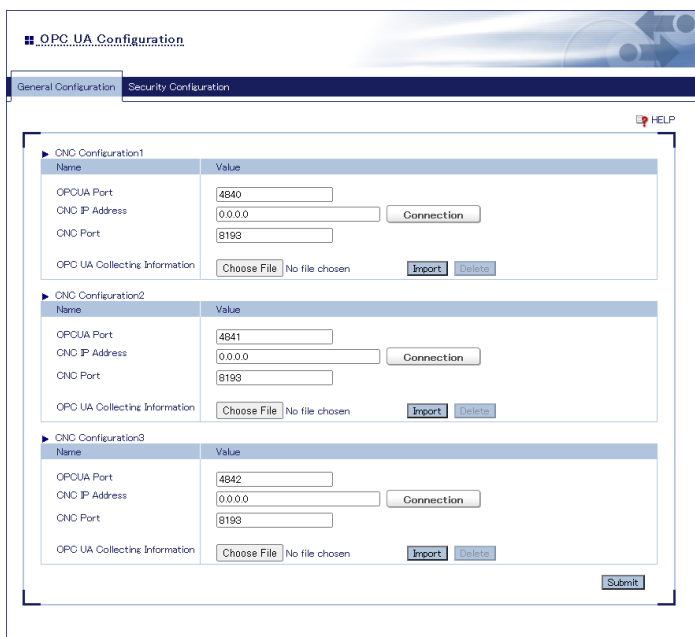

4. Check the settings and click **Submit**.



Note

- The entered settings will be cleared if other configuration items are clicked on the menu. To save the entered settings, click **Submit**.

5. The confirmation message for restart is displayed.

To continue the configuration, click a link to the configuration.

Click **Restart** to take effect of the new setting when the necessary configuration is finished.

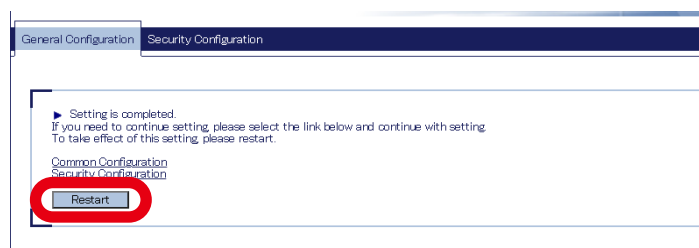

TIP

- Do not turn off FBR-100AN/FBR-100 when the restart is in progress.



Note

- FBR-100AN/FBR-100 can also be restarted by clicking **Restart** from the configuration menu.

6. When the restart is finished and the login page of FBR-100AN/FBR-100 is displayed again, the configuration is completed.

A-5. Using Modbus TCP Activation

The following explains the basic procedure to use the Modbus TCP function of FBR-100AN/FBR-100.

A-5-1. Features of Modbus TCP

- By applying Modbus TCP activation, FBR-100AN/FBR-100 can operate in Modbus TCP (slave).
- The upper Modbus TCP (master) device can collect the information of CNC via the slave device.
- The standard MT-Connect function of FBR-100AN/FBR-100 cannot be used at the same time.
- Only FANUC CNC is supported.
- It is possible to collect only the information that can be collected at the default point.
- Up to 10 macro variables can be collected.
- Up to 130 PMCs can be collected when the address type is 4 bytes.

[System configuration]

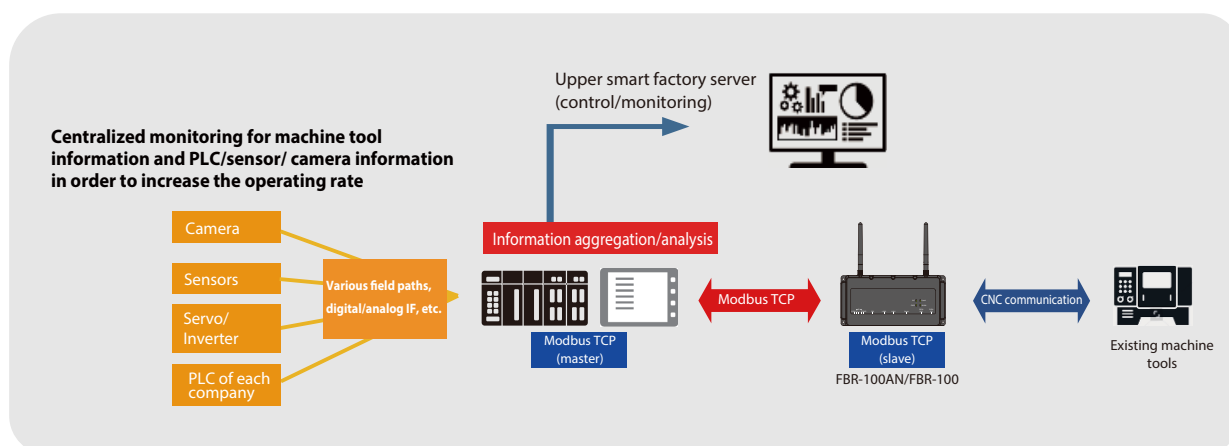

- To use the Modbus TCP activation, the activation key needs to be registered in advance. For details, refer to **A-3-1. Registering Activation Key**.

A-5-2. Communication for Using Modbus TCP Activation

FBR-100AN/FBR-100 can operate as Modbus TCP (slave) and return CNC information in response to the command requested by the upper Modbus TCP (master).

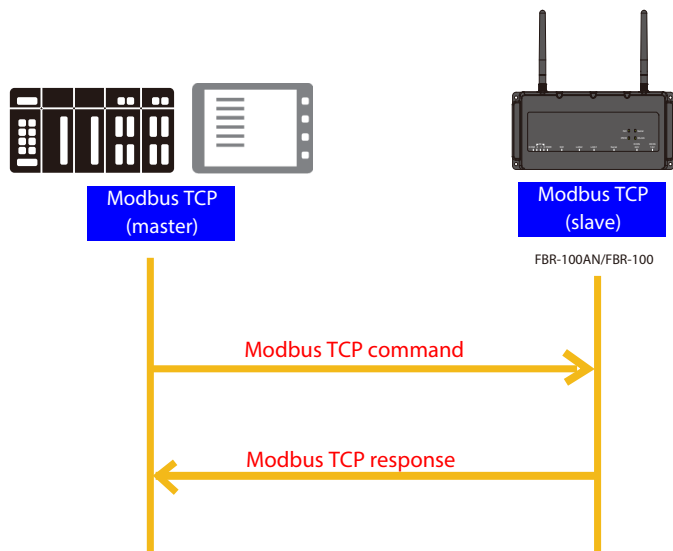

- Only one Modbus TCP (master) can be connected.
- The master device can specify the maximum 125 words for a read size (compliant with Modbus TCP specifications).
- Only Function code 0x03 (for reading the holding register value) and Function code 0x04 (for reading the input register value) can be used as commands. Other code (write code, etc.) is not supported.
- The character string is ASCII code. An ASCII code will be returned even for a numerical value (a numerical value will be returned only for PMC and Tool Offset).
- Set the address by a word (2 bytes), and set the character string by 1 byte. The byte order is big endian.

[Data setting sample]

Type	Value	Data
String	abc	0x6162 0x6300
Numerical value	12345	0x3039

- PMC would be a little endian when it is obtained from CNC. The endian conversion setting can be configured from the FBR-100AN/FBR-100's Web Page.

When the NTP client is enabled, FBR-100AN/FBR-100 starts after synchronizing the time with the NTP server. If the synchronization does not finish in 120 sec, FBR-100AN/FBR-100 starts without it.



Note

- FBR-100AN/FBR-100 does not include software or hardware that supports Modbus TCP (master). Please prepare the commercially-available one that can work as Modbus TCP (master).
- For the CNC devices that can be used by this activation and the detailed configuration method, see the FBR-100AN/FBR-100's catalog or visit our website.
- The details of endian conversion function can also be found on the application note that is posted on the Silex Technology's website.

A-5-3. Showing Modbus TCP Status

Modbus TCP status shows the Modbus TCP setting.

1. Open your Web browser and access the FBR-100AN/FBR-100's Web page.



Note

- For details on how to access the FBR-100AN/FBR-100's Web page using the Web browser, refer to **3-2-2. Displaying FBR-100AN/FBR-100's Web Page.**

2. Click **Modbus TCP** from the configuration menu.

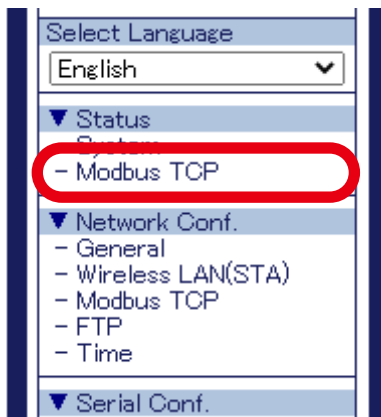

3. The **Modbus TCP Status** page is displayed.

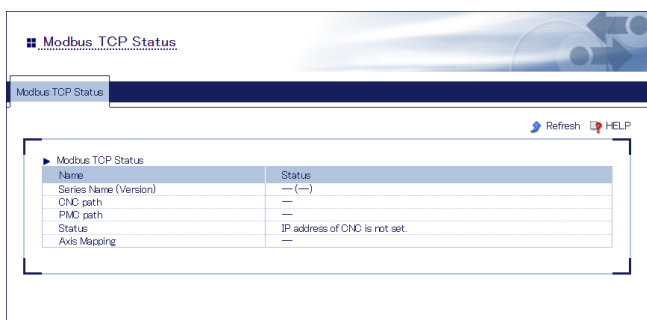

A-5-4. Modbus TCP Setting

The following explains how to configure the Modbus TCP setting.

For details, see the reference documents that can be found on the Silex Technology's website.

1. Open your Web browser and access the FBR-100AN/FBR-100's Web page.



Note

- For details on how to access the FBR-100AN/FBR-100's Web page using the Web browser, refer to **3-2-2. Displaying FBR-100AN/FBR-100's Web Page.**

2. Click **Modbus TCP** from the configuration menu.

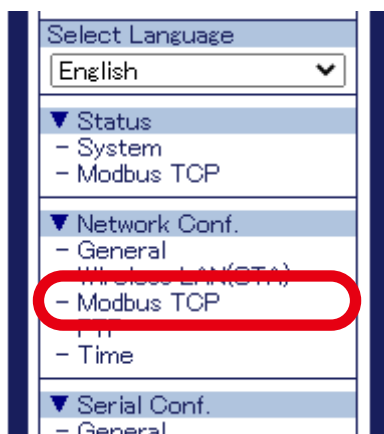

3. The **Modbus TCP Configuration** page is displayed. Configure each setting.

Modbus TCP Configuration

Modbus TCP Configuration

HELP

General Configuration

Name	Value
Modbus TCP Port	502
CNC IP Address	0.0.0.0 <input type="button" value="Connection"/>
CNC Port	8193
Byte Swapping/Endian(PMC)	DISABLE

CNC Information Configuration

Name	Value
	<input type="button" value="All ON"/> <input type="button" value="All OFF"/>
	Collection Interval(ms)
Emergency Stop Status	ON 800
Operator Messages Display	ON 1000
Alarm Messages Display	ON 800
CNC Operating Mode	ON 800
Number of Parts	ON 1000
CNC Operating Status	ON 800
Absolute Position	ON 800
Feed Speed	ON 800
Sequence Number of Executing Program	ON 800
Main Program Name	ON 2000
Main Program Comment	ON 2000
Tool Number	ON 800
Feed Speed Override	ON 1000
Block of Executing Program	ON 800

4. Check the settings and click **Submit**.



Note

- The entered settings will be cleared if other configuration items are clicked on the menu. To save the entered settings, click **Submit**.

5. The confirmation message for restart is displayed.

To continue the configuration, click a link to the configuration.

Click **Restart** to take effect of the new setting when the necessary configuration is finished.

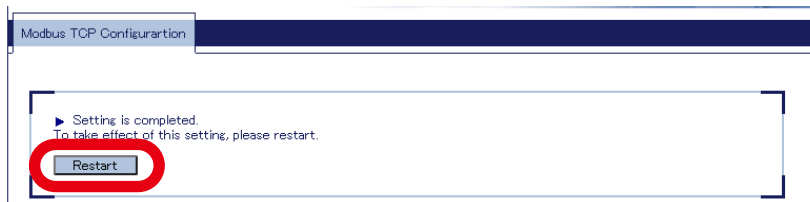

TIP

- Do not turn off FBR-100AN/FBR-100 when the restart is in progress.



Note

- FBR-100AN/FBR-100 can also be restarted by clicking **Restart** from the configuration menu.

6. When the restart is finished and the login page of FBR-100AN/FBR-100 is displayed again, the configuration is completed.