

Protocol Converter for CNC Machines FBR-100AN / FBR-100 Setup Guide

Silex technology English CE UK CA WA105300XF

Thank you for purchasing "FBR-100AN" / "FBR-100", the MTConnect-compatible protocol converter for CNC devices (hereinafter the "FBR-100AN" / "FBR-100"). This setup guide explains how to configure FBR-100AN / FBR-100.

How to Download User's Manual

The user's manual can be downloaded from Silex Technology's website.

- 1 Access the website below:
URL: <https://www.silextechnology.com/>
- 2 Go to the support page and download the user's manual.

Product Name	FBR-100AN or FBR-100
User's Manual	FBR-100AN / FBR-100 User's Manual

Parts and Functions

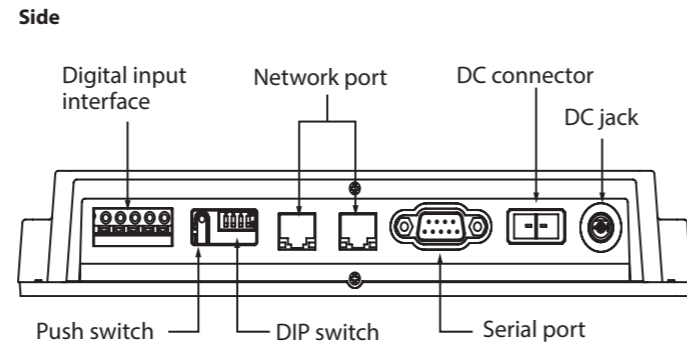

DC Connector

PIN Number	Signal Name	Description
1	DCIN	DC 12-24VIn±5%
2	GND	GND

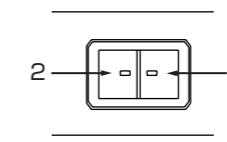

DC connector : JST's S02B-F32SK-GGXR(LF)(AU)

To connect to this connector, please use JST's JFA connector J300 series F32F5S-02V-KX.

For detailed specifications of each interface, refer to the user's manual of FBR-100AN / FBR-100.

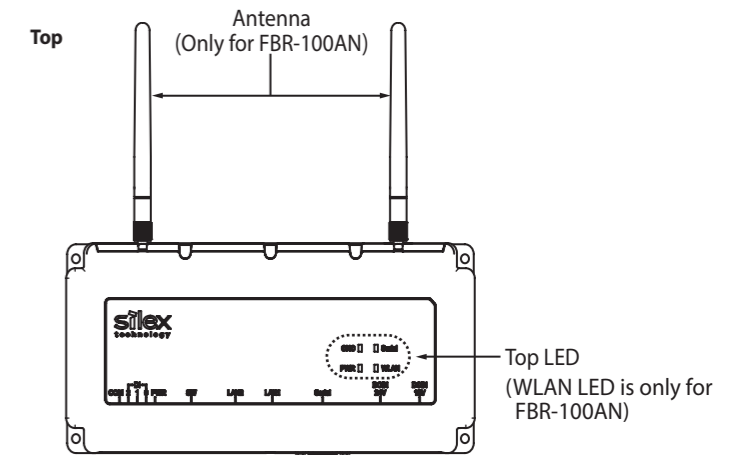

Step 1 Before You Begin

Connecting FBR-100AN / FBR-100 to PC

Connect FBR-100AN / FBR-100 directly to the PC.

- 1 Connect one end of LAN cable to LAN1 of FBR-100AN / FBR-100 and the other end to PC. (1)
If you have an activation key to enable the optional function, turn on the DIP switch 4.
- 2 Turn on FBR-100AN / FBR-100 by one of the following methods. (2)
- Connect the AC adapter to DC jack and the AC adapter's plug to the outlet.
- Connect the DC cable to DC connector.
TIP - When AC adapter is used to supply power to FBR-100AN / FBR-100, please always use the correct AC adapter. Use of incorrect AC adapter may cause malfunction.
- AC adapter of FBR-100AN / FBR-100 is an optional item.
- 3 When FBR-100AN / FBR-100 is turned on, the PWR LED turns green on top of the unit.

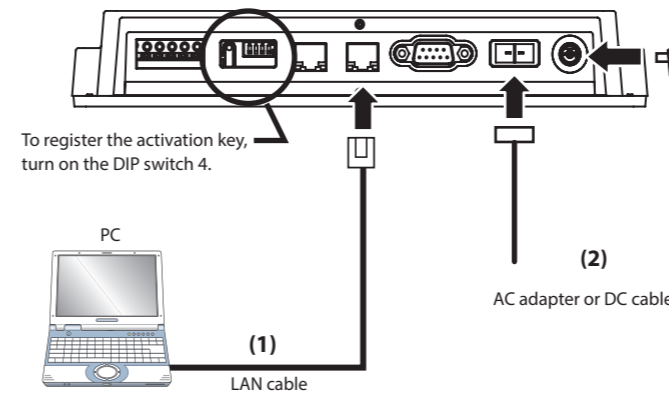

Changing the Network Setting of PC

To allow access to FBR-100AN / FBR-100, change the network setting of PC.

For the LAN1 of FBR-100AN / FBR-100, the Class C IP address (192.168.1.1) is configured by defaults. For the PC's address, use a different address that is not used by FBR-100AN / FBR-100.

Sample setting)
When the default IP address (192.168.1.1) is configured to FBR-100AN / FBR-100, configure the network settings of PC as follows:
IP address : 192.168.1.123
Subnet mask : 255.255.255.0

Step 2 Network Configuration

FBR-100AN / FBR-100 supports HTTP. By entering the IP address of FBR-100AN / FBR-100 to the address bar of your Web browser, the Web configuration page can be accessed.
The network settings of FBR-100AN / FBR-100 can be configured from its Web configuration page.

Displaying FBR-100AN / FBR-100's Web Page

- 1 Start the Web browser on the PC.
Note Recommended Web browser : Microsoft Edge
- 2 Enter the IP address of FBR-100AN / FBR-100 (xxx.xxx.xxx.xxx) to the address bar and press the Enter key.
Note The default IP address of FBR-100AN / FBR-100 is "192.168.1.1".

- 3 The login password configuration page will be displayed. Enter the login password to configure for FBR-100AN / FBR-100 and click **Submit**.

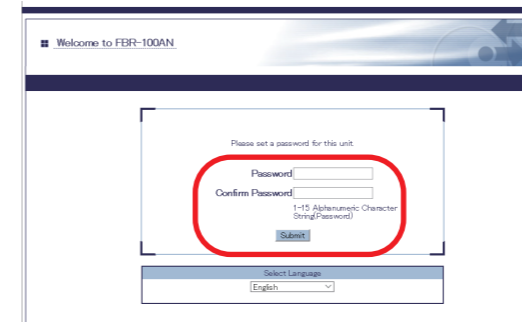

TIP - The login password configuration page is displayed only when FBR-100AN / FBR-100 is configured for the first time.

- 4 When the login page is displayed, enter the login password for **Password** and click **Login**.

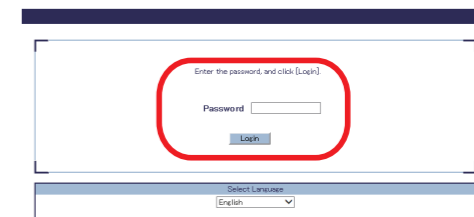

- 5 The Web page of FBR-100AN / FBR-100 is displayed.

When the DIP switch 4 is turned off and then FBR-100AN / FBR-100 is started (when FBR-100AN / FBR-100 is started using the factory default setting), configure the network settings appropriate for your environment.

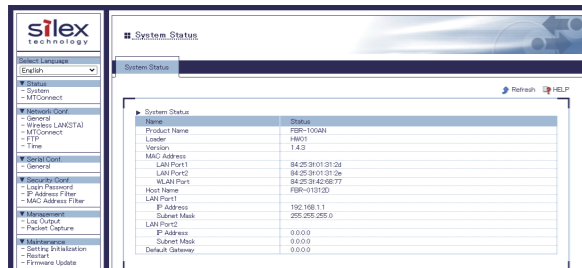

When the DIP switch 4 is turned on and then FBR-100AN / FBR-100 is started, register the activation key.

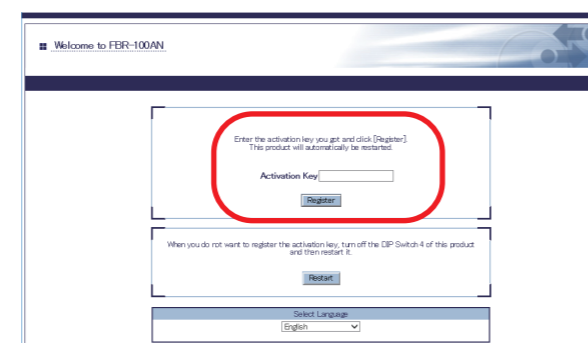

Basic Configuration

Configure the basic settings.

- 1 Click **General** from the configuration menu.

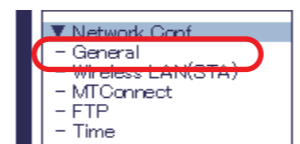

- 2 The **General Configuration** page is displayed. Configure the settings and click **Submit**.

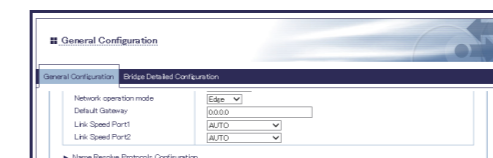

Note - For details on each configuration item, please refer to the user's manual. The user's manual can be downloaded from the Silex Technology's website. For how to download the user's manual, see **How to Download User's Manual** in this setup guide.
- When you want to use the bridge function to communicate with the devices that do not respond to the MAC address broadcast, register the address management table on the **Bridge Detailed Configuration** tab.

- 3 A confirmation message for restart is displayed. Click **Restart** to restart FBR-100AN / FBR-100 to take effect of the new settings.

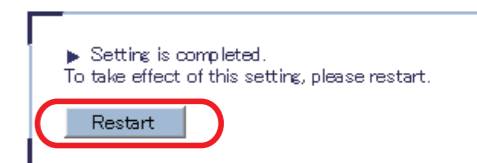

Basic Configuration

The basic configuration has been completed. Continue the configuration to use the wireless station function and

To use FBR-100AN in wireless LAN : (* Not applicable to FBR-100)
Go on to **Using FBR-100AN as Wireless Station**.

To use FBR-100AN / FBR-100 in wired LAN :
Go on to **MTConnect Setting**.

Using FBR-100AN as Wireless Station (* Not applicable to FBR-100)

Configure the network setting to use FBR-100AN as a wireless station.

- 1 Click **Wireless LAN(STA)** from the configuration menu.

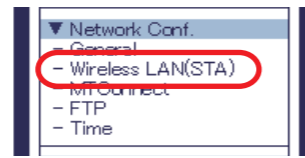

- 2 Click **Easy Configuration** or **Detailed Configuration**. Configure the displayed settings and click **Submit**.

Note For details on each configuration item, please refer to the user's manual. The user's manual can be downloaded from the Silex Technology's website. For how to download the user's manual, see **How to Download User's Manual** in this setup guide.

Easy Configuration

From a list of the discovered wireless networks, select one to connect and then enter the network key (WEP Key or Pre-Shared Key).

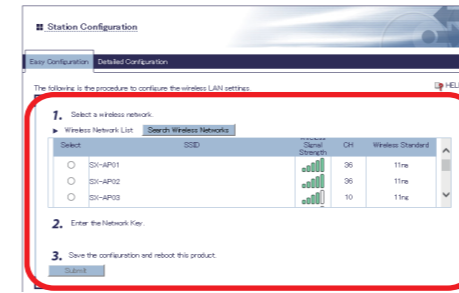

Detailed Configuration

Enter the information of Access Point to connect in wireless LAN.

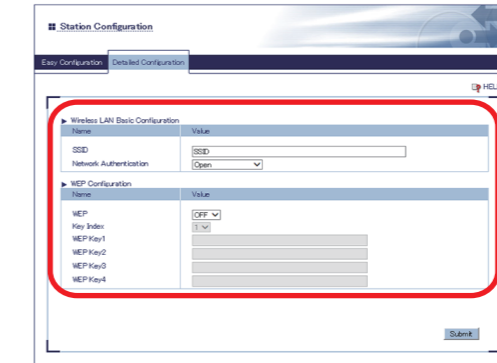

- 3 A confirmation message for restart is displayed. Click **Restart** to restart FBR-100AN to take effect of the new settings.

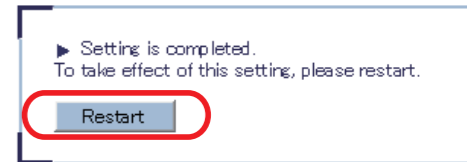

The configuration is completed.

MTConnect Setting

Configure the setting to use MTConnect.

- 1 Click **MTConnect** from the configuration menu.

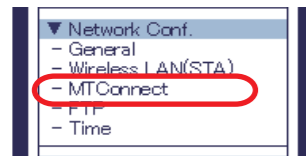

- 2 The **MTConnect Configuration** page is displayed. Configure each setting and click **Submit**.

Note For details on each configuration item, please refer to the user's manual. The user's manual can be downloaded from the Silex Technology's website. For how to download the user's manual, see **How to Download User's Manual** in this setup guide.

To create a file to import, use a point file creation utility or device information creation utility.

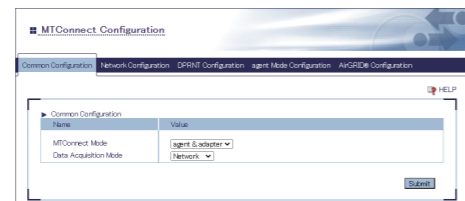

- 3 Configure the detailed settings according to **Data Acquisition Mode** you have selected. Click **Network Configuration**, **DPRNT Configuration**, **agent Mode Configuration** or **AirGRID® Configuration**.

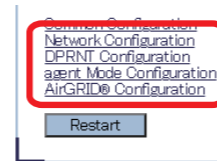

- 4 Configure the displayed settings and click **Submit**.

Network Configuration

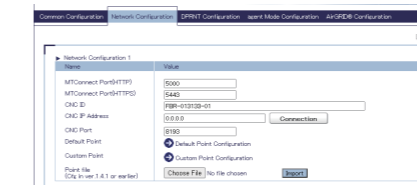

DPRNT Configuration



agent Mode Configuration



AirGRID® Configuration

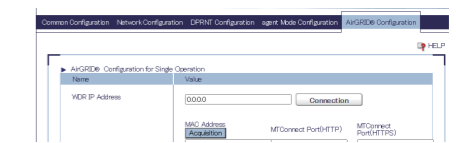

- 5 A confirmation message for restart is displayed. When necessary configuration is completed, click **Restart** to restart FBR-100AN / FBR-100 to take effect of the new settings.

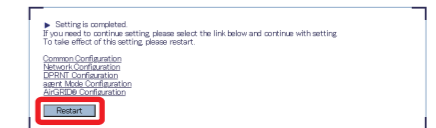

The configuration is completed.

Step 3 Installing and Using FBR-100AN / FBR-100

After the configuration is finished, install and fix FBR-100AN / FBR-100 to the location of use. When using FBR-100AN / FBR-100 over wired LAN, be sure to connect FBR-100AN / FBR-100 to the network using a LAN cable before you turn on FBR-100AN / FBR-100. To fix FBR-100AN / FBR-100 to the location of use, you can use either the mounting stays on the product case or use the DIN rail mounting plate that is commercially available in the market.

Note - DIN rail and DIN rail mounting plate are not contained in the product package. They need to be purchased separately.
- Recommended DIN rail mounting plate : TAKACHI DRP5-9W
- For the mounting screw, tapping screw (for plastic) is recommended.
Nominal diameter : 3mm
Nominal length : 10-13mm

Fixing a DIN rail mounting plate to FBR-100AN / FBR-100

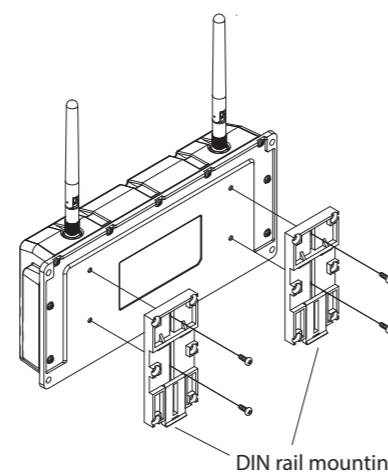

Fixing a DIN rail mounting plate to a DIN rail

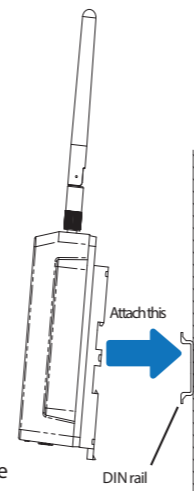

Appendix

Factory Default Configuration Using Push Switch

The following explains how to reset FBR-100AN / FBR-100 to factory defaults. The factory default configuration can be executed using the push switch of FBR-100AN / FBR-100.

Note If you can access the Web page of FBR-100AN / FBR-100, click **Setting Initialization** from the menu, select **All** for **Select the target device to initialize** and click **Execute**.

- 1 Turn off FBR-100AN / FBR-100 by unplugging the DC cable or AC adapter.
- 2 Press and hold the push switch on the front side of FBR-100AN / FBR-100 while plugging the DC cable or AC adapter back into FBR-100AN / FBR-100. Keep pressing.
- 3 When all LEDs on top of FBR-100AN / FBR-100 turn orange, and then all LEDs except for the PWR LED turn off, release the push switch.
- 4 When the PWR LED turns green, the factory default configuration is completed.

Customer Support Center

If you have any questions, please contact us at the following.

Customer Support Center information

	E-mail
USA ;	support@silexamerica.com
Europe;	support@silexeurope.com